

SPINKS SCALES

INSTRUCTIONS/OPERATOR'S MANUAL

For

ROOSTER SCALES

MODELS:

250 #

350 #

600 #

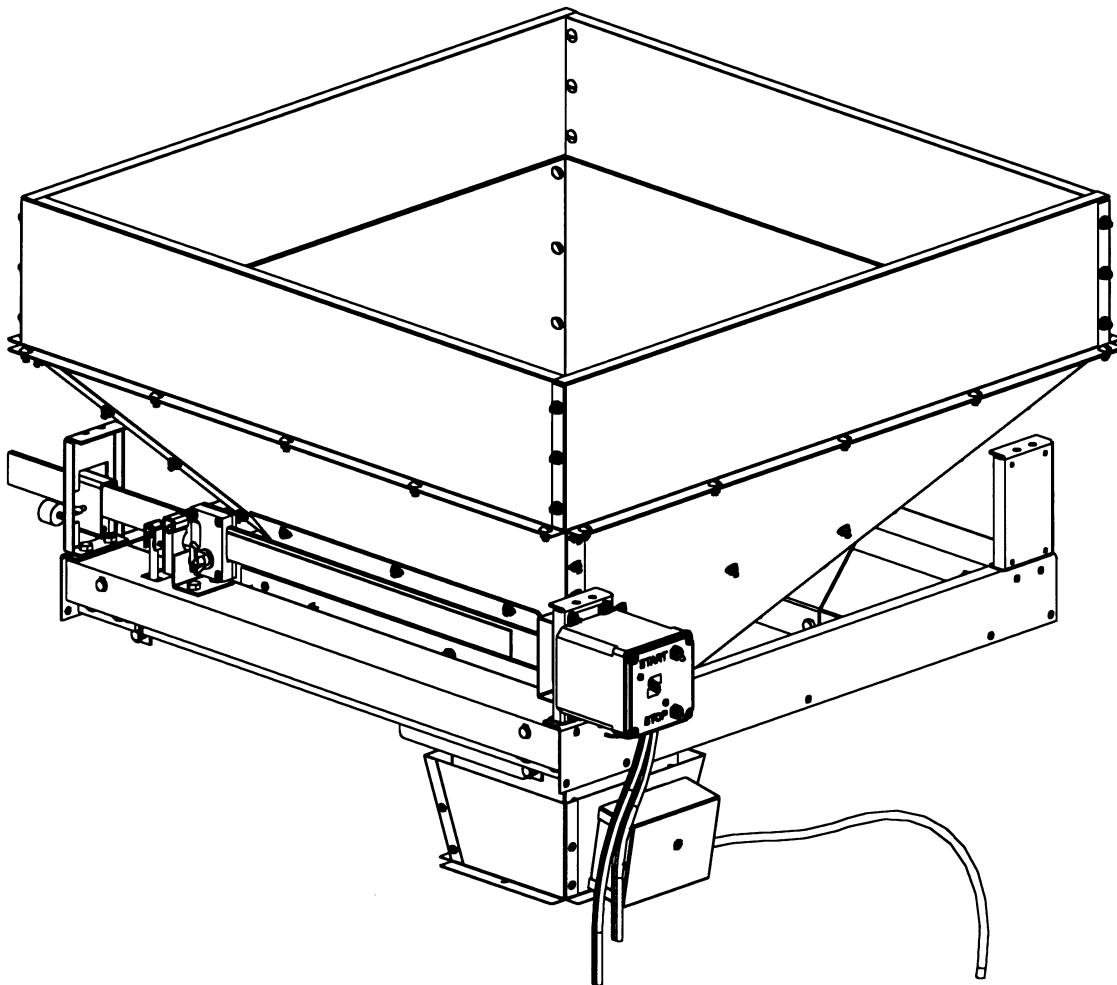

TABLE OF CONTENTS

HANGING SCALESPages 3-4

CONTROL BOX INSTALLATION Page 5

SHACKLE & BEAM CHECK Page 6

HOPPERS, STANDARD & LOW PROFILEPages 7-8

TESTING “M” CONTROL BOX & BEAM Page 9

TESTING “M2L” CONTROL BOX & PRESSURE SWITCH Page 10

“M” CONTROL BOX SCHEMATIC Page 11

“M2L” CONTROL BOX SCHEMATIC Page 12

OPERATING SCALE.....Pages 13-14

600 LB SCALE SUPPLEMENT.....Pages 15-16

ROOSTER SCALE INSTALLATION GUIDE LINES

STEP 1. After the rooster feeder is winched and cabled, you will need to find the location for the four (4) cable pulleys required to support the scale and hopper assembly. Suggested boards for support (2" x 6" min) lagged correctly into trusses. For standard hoppers, eyebolts should be spaced apart 27-1/2" x 30-3/4". For low profile hoppers, eyebolts should be spaced apart 38-1/8" x 32". See Fig. 1.

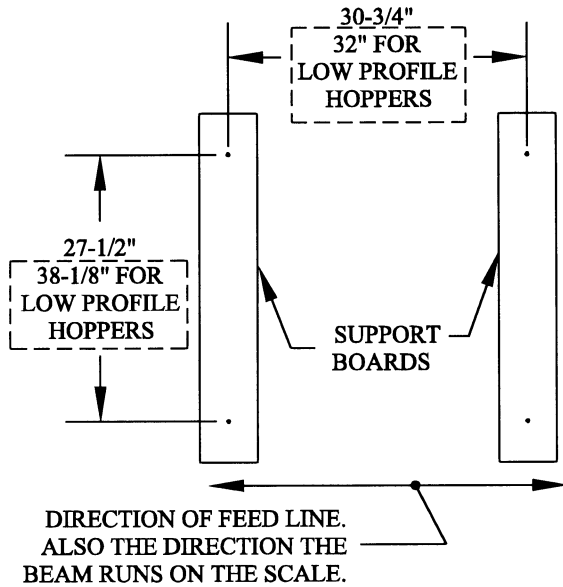

FIG. 1

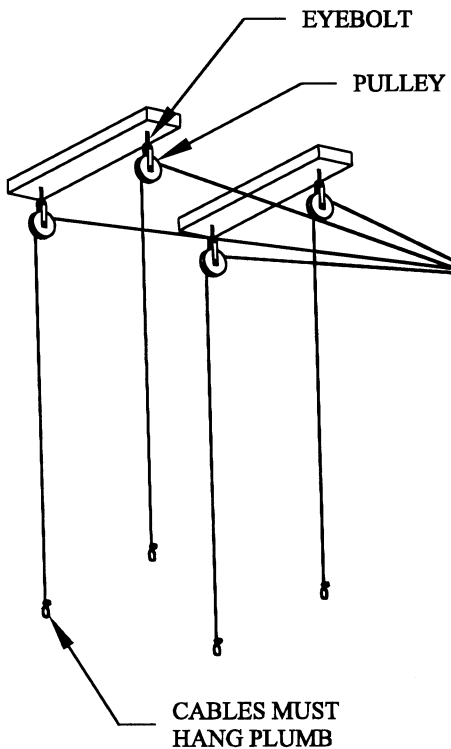

FIG. 2

STEP 2. These should be spaced evenly from the center of the feed line hopper so that when the eyebolt and pulleys are mounted and the cables are attached to the winch line the cables will hang plumb. Refer back to Fig. 2.

STEP 3. Remove the plastic ties (2) used to secure cross bars during shipping. See Fig. 3.

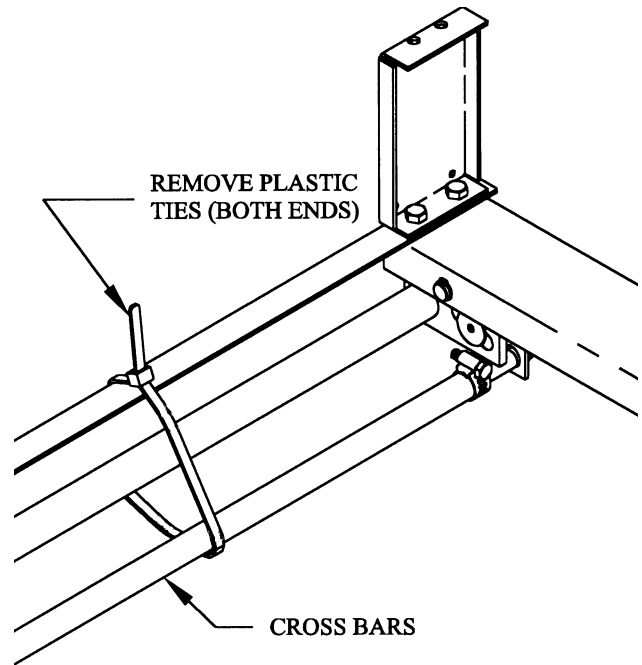

FIG. 3

STEP 4. For use with the low profile hopper (for other hoppers skip to step 6), attach the extended brackets (2) to each of the side rails using the 5/16-18 x 3/4" hex screws (3) & 5/16-18 hex flange nuts (3). The hardware and brackets come with the hopper. See Fig. 4.

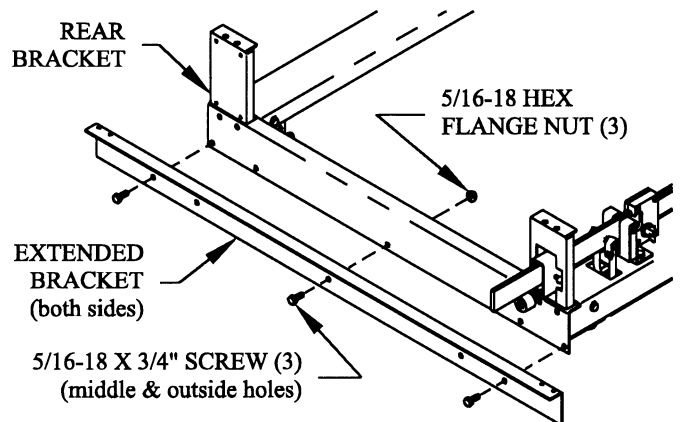

FIG. 4

STEP 5. (This step for scales using low profile hopper – others skip to step 6) The scale is suspended from the two extended brackets. Thread the cable in and out through the two holes found at the top of the brackets. See Fig. 5. Be sure the scale is installed level.

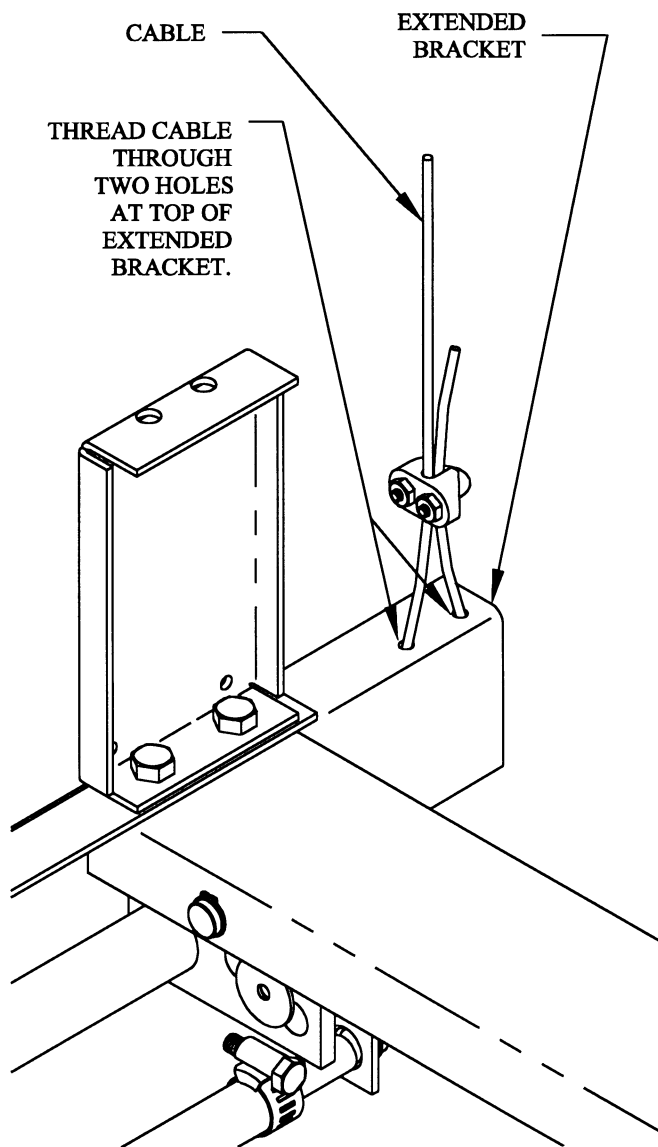

FIG. 5

STEP 6. (This step is for scales using the standard type hopper – for scales using low profile hoppers, skip to step 7) The scale is suspended from four suspension brackets. Thread the cable in and out through the two holes found at the top of the brackets. See Fig. 6. Be sure the scale is installed level.

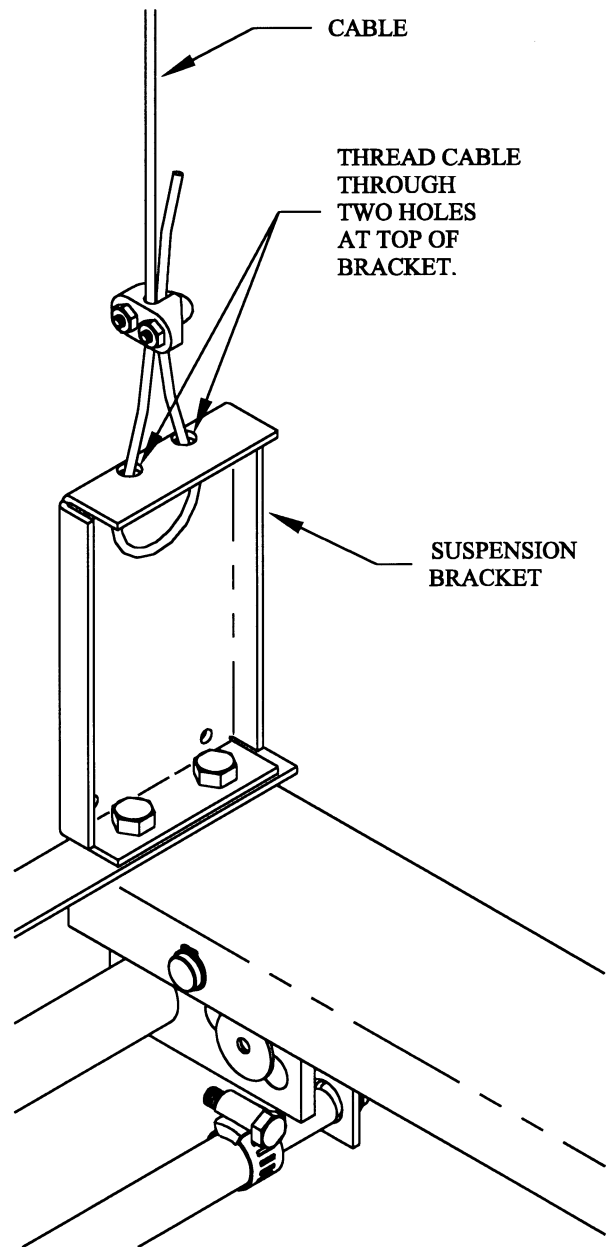

FIG. 6

STEP 7. **NOTE: Your scale either came with an “M” type control box (one control box) or an “M2L” type control box (two control boxes). For M2L type control boxes skip to step 8.**

Remove (and retain) the four nuts and washers that secure the trig loop to the right front suspension bracket. Attach control box to the right front suspension bracket, securing with the four nuts, washers and screws. Make certain that the trig loop is secure. See Fig. 7A. The ground wire should be attached between the control box and the right front suspension bracket. See Fig. 7B.

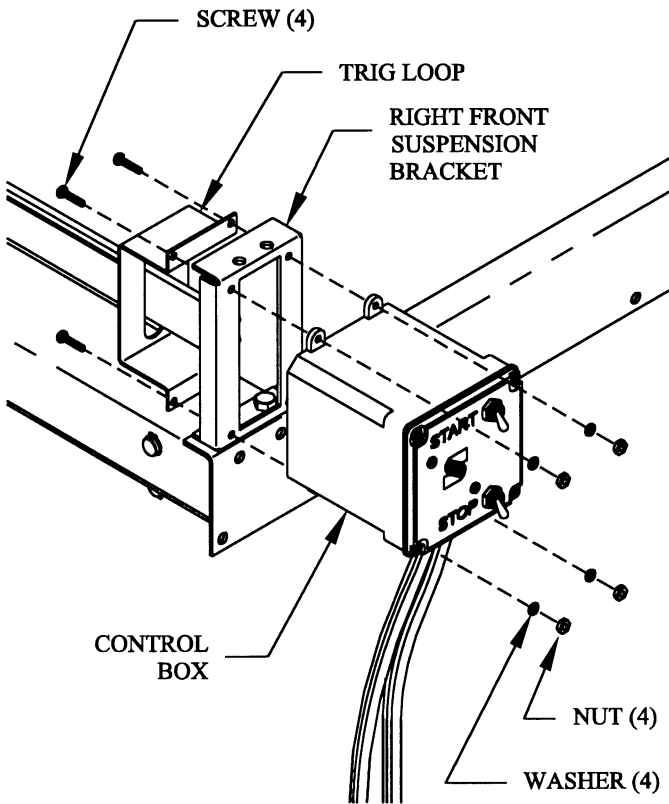

FIG. 7A

STEP 8. NOTE: If you do not have the M2L type control box, skip to step 9.

Attach the first control box (both boxes are connected to each other by a cord – the first control box has two switches and magnets on the other end) as detailed in step 7 and shown in Fig. 7A & 7B. Attach the second control box (the one without magnets, but with one switch and one red light “power on” indicator) to the rear right suspension bracket. Secure with screws, washers & nuts (included in your hardware package). See Fig. 8.

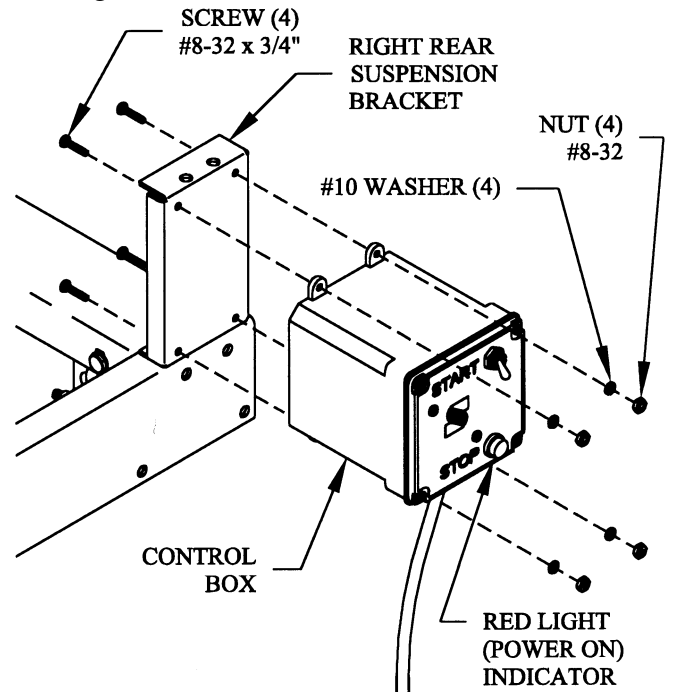

FIG. 8

STEP 9. At this point, insure the following:

A) The scale is level and secure. If the scale is not level repeat step 2 until it is. See Fig. 9.

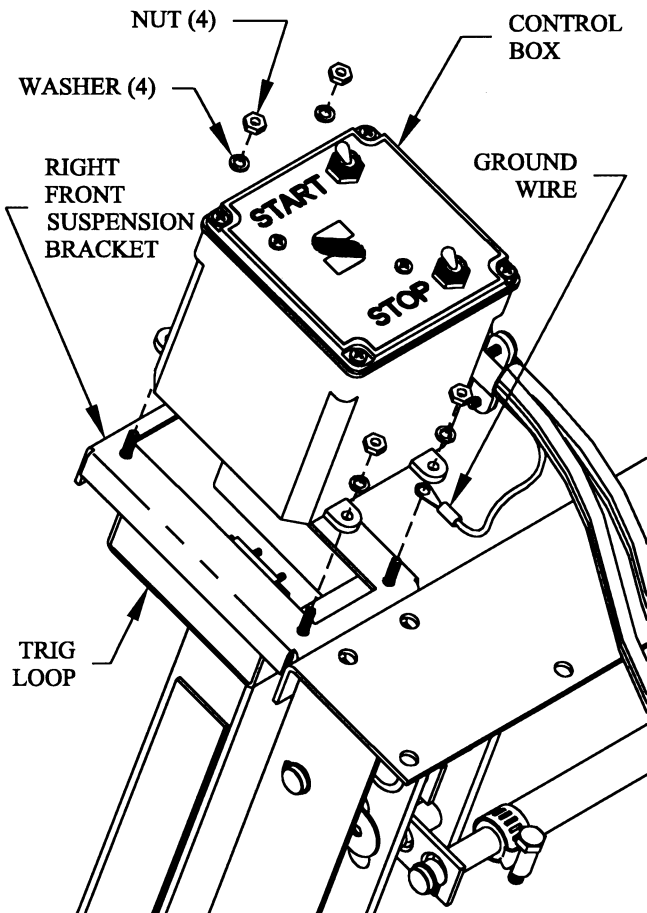
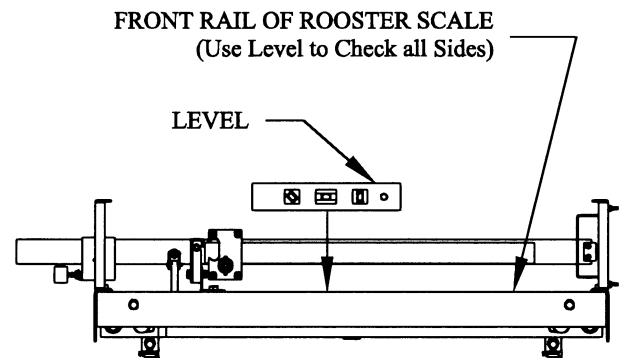

FIG. 7B



FRONT VIEW
ROOSTER SCALE SHOWN
W/O CONTROL BOX

FIG. 9

B) The levers are hanging properly – shackles nestled in the grooves in the pins. See Fig. 10 & 11.

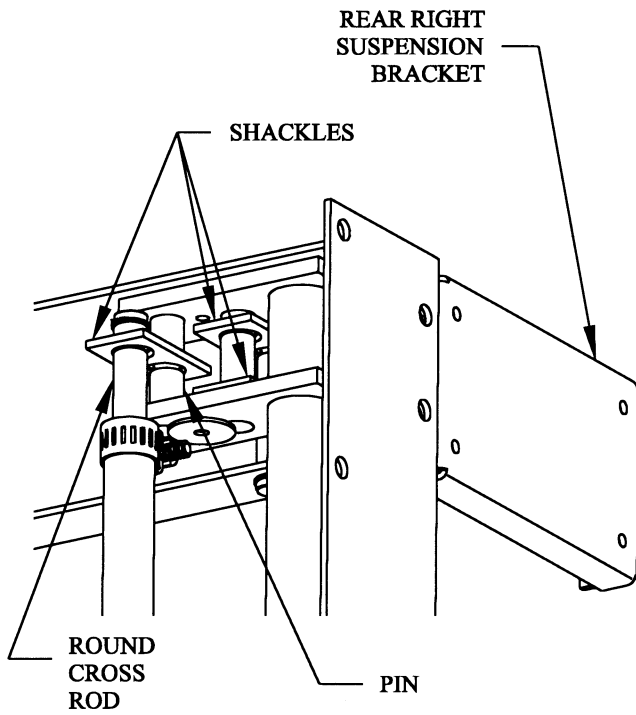

VIEWED FROM UNDERNEATH

FIG. 10

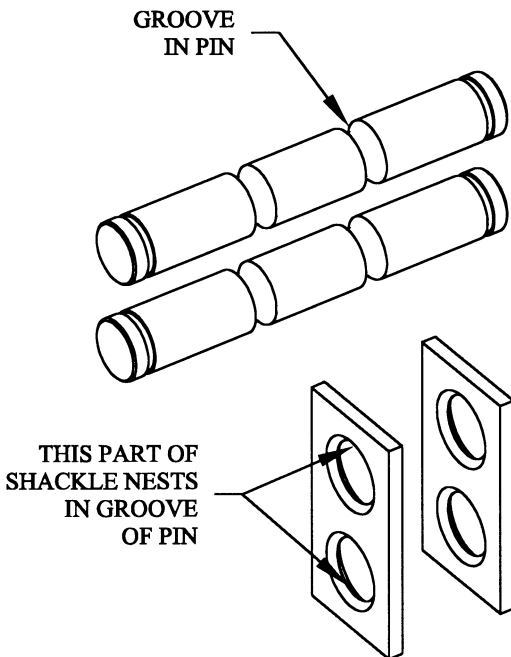

NOTE: SHACKLES & PINS SHOWN SEPERATE FOR CLARITY. THERE ARE 14 SHACKLES IN THE SCALE. ALL SHOULD BE CENTERED IN GROOVES AS SHOWN.

FIG. 11

C) Insure that the beam is sitting properly in bearing. The loop bearing should be placed on the back pivot of beam. See Fig. 12.

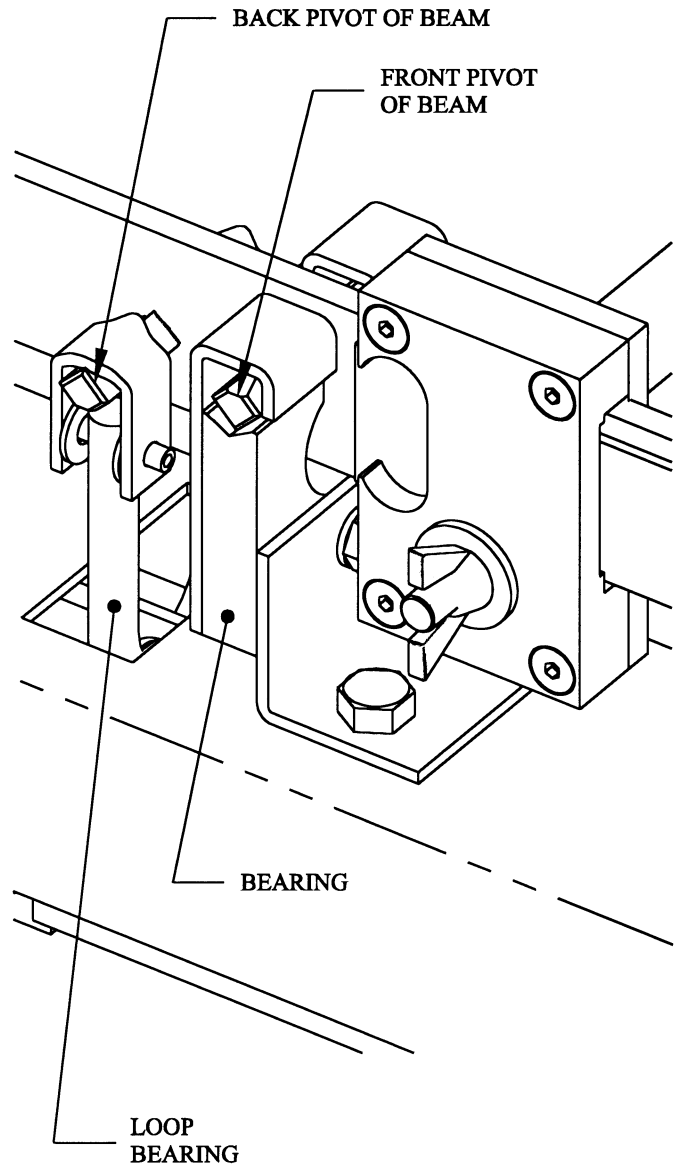

FIG. 12

D) Beam flows freely without catching. See Fig. 13.

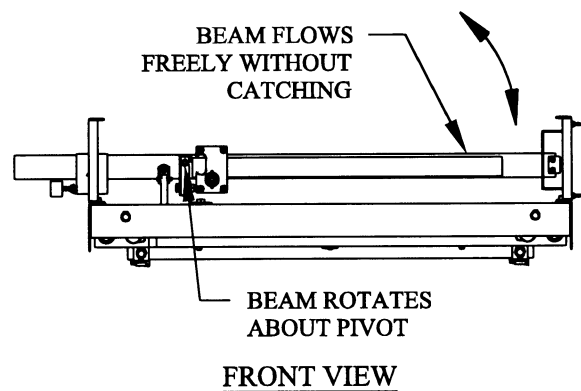

FIG. 13

STEP 10. Assemble hopper and gate adapter per hopper instructions.

STEP 11. Attach the female adapter to the unloader. See Fig. 14. Either use hardware supplied with unloader (cotter pins) or 1/4-20 screws and nuts from the rooster scale hardware bag.

Note: If using screws and nuts it may be necessary to enlarge the holes by drilling.

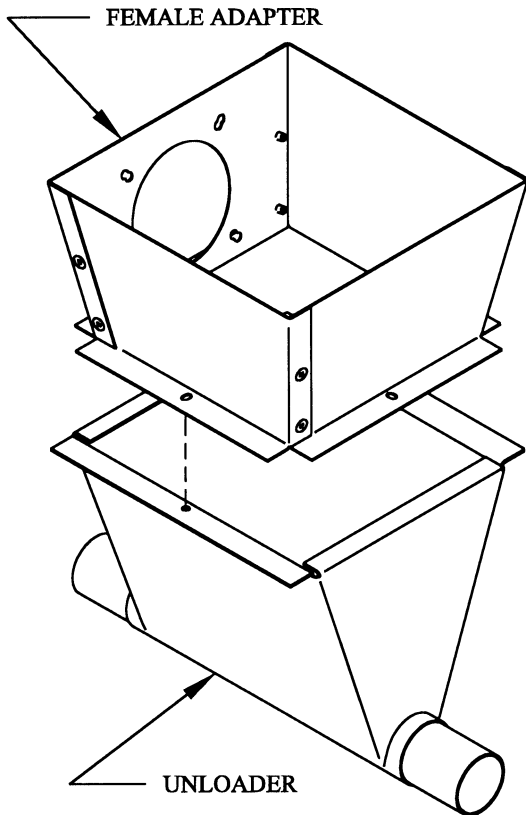

FIG. 14

STEP 12. Attach the galvanized hopper support bars (included with scale) to the hopper. See Fig. 15 (for standard hopper) or Fig. 16 (for low profile hopper).

If you've chosen to use a hopper other than one of Spink's models, you may have to mark and drill holes using the dimensions of the hole spacing on the support bars. If so, drill 11/32" holes after carefully making **exact** markings so that the support bars will fit in the same place (top to bottom as well as side to side) on either side of the hopper. This is important to insure that the hopper will be level.

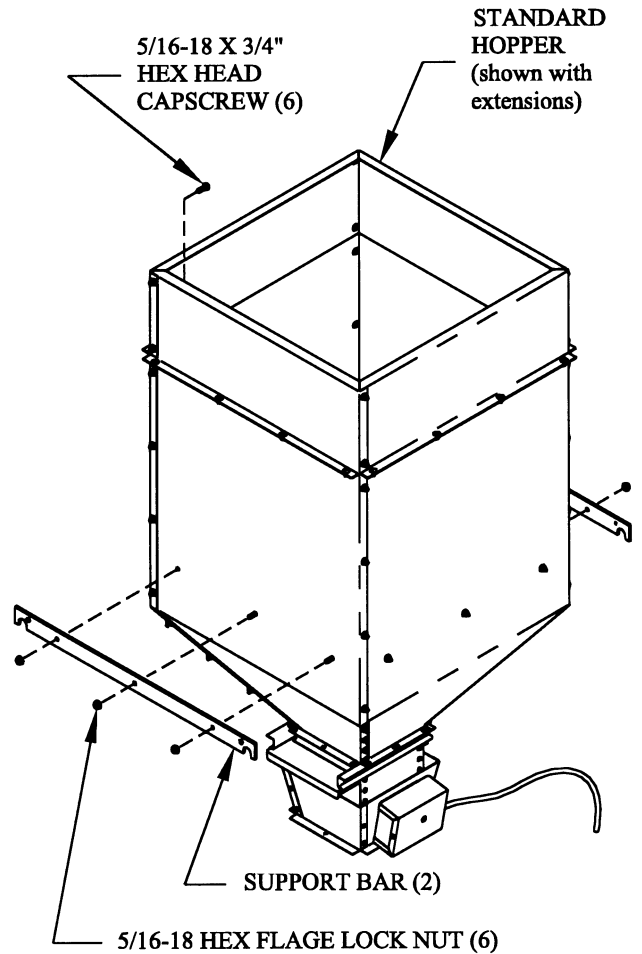

FIG. 15

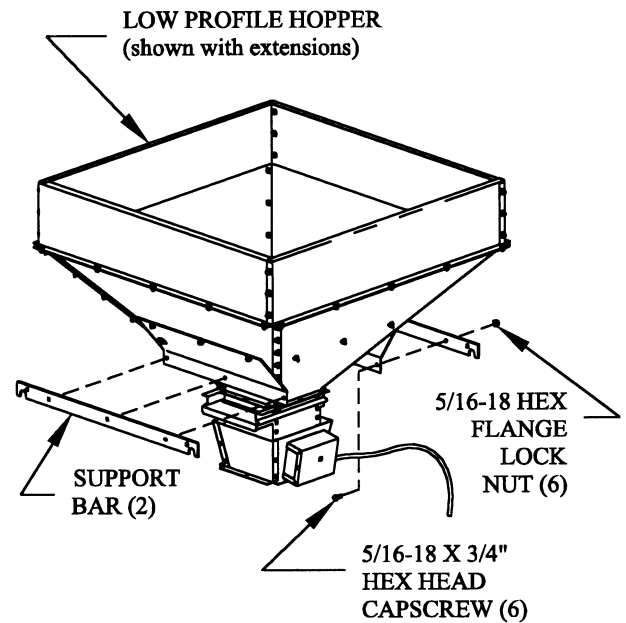

FIG. 16

STEP 13. Place hopper on scale fitting the slots on the hopper support bars on the cross bars on the scale. Make sure the gate will pull open on the same side as beam for convenience. See Fig. 17.

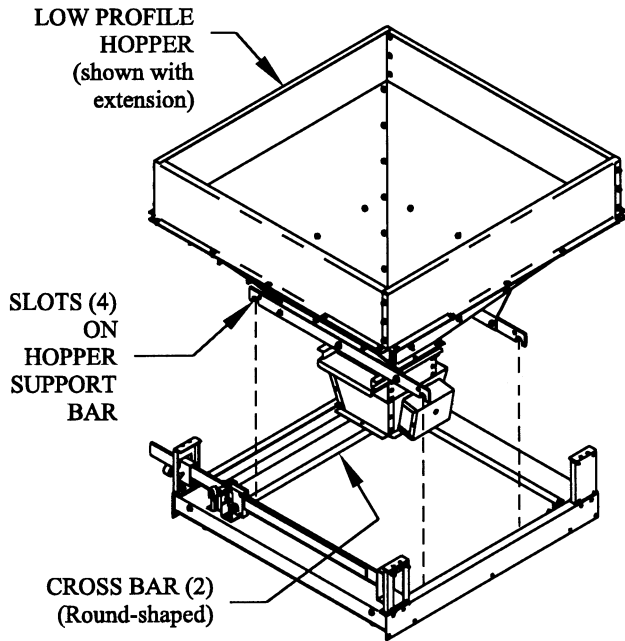
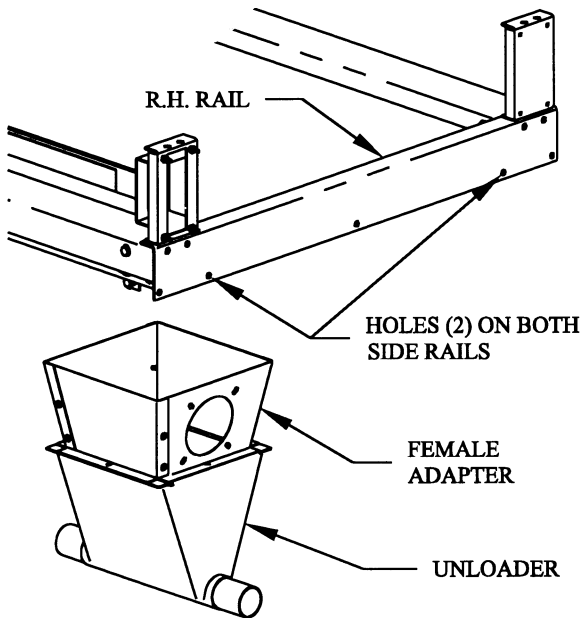

FIG. 17

STEP 14. Suspend the unloader and female adapter from the left and right hand rails on the scale. Cables (not supplied) are often used to accomplish this. Use the two inside holes (but not the center hole) on each side rail. See Fig. 18.



ROOSTER SCALE SHOWN W/O CONTROLS, HOPPER & PRESSURE SWITCH (for clarity)

FIG. 18

STEP 15. Be sure hopper is centered with at least 1/2" clearance on all sides between the gate assembly and the female adapter. See Fig. 19. Secure hopper by using the hose clamps found on the cross bars. Slide the hose clamps against hopper support bars and tighten. See Fig. 20.

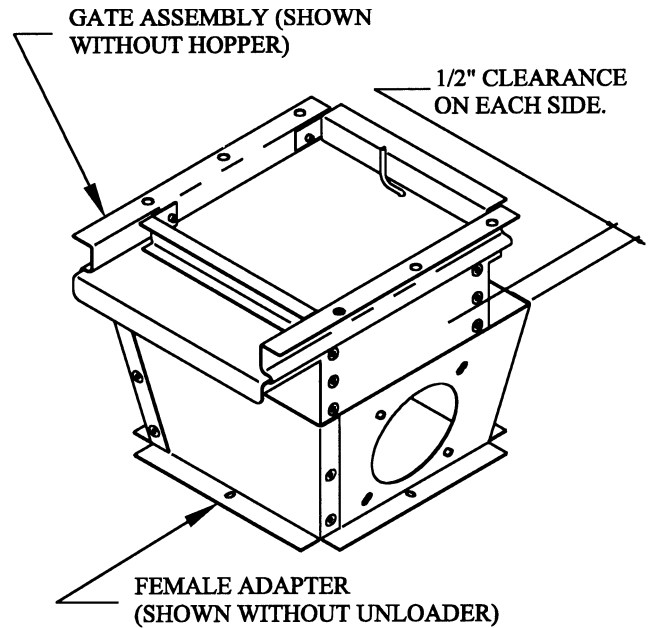

FIG. 19

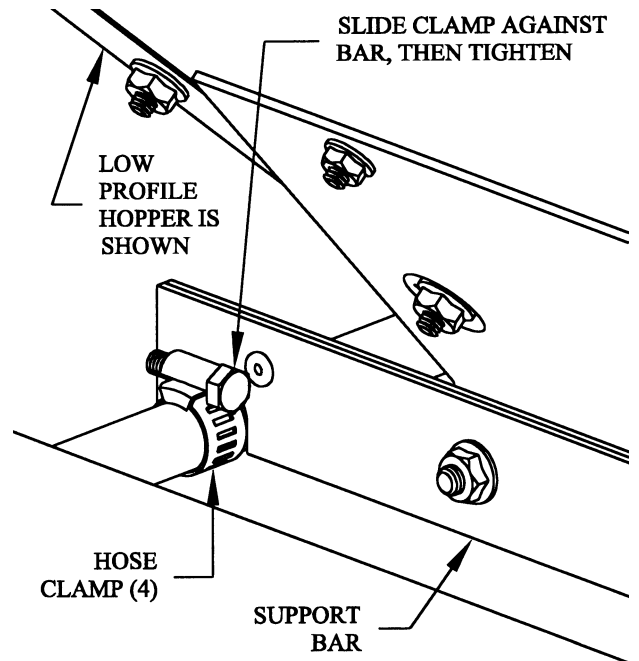

FIG. 20

STEP 16. Position the LB/KG poise to zero and tighten. See Fig. 21.

Course adjustment of zero is accomplished by moving the back balance block on the back of the beam. Fine adjustment is accomplished by screwing the balance ball in or out. See Fig. 22.

Make sure the magnetic switches are in alignment at the beam and control box. See Fig. 23.

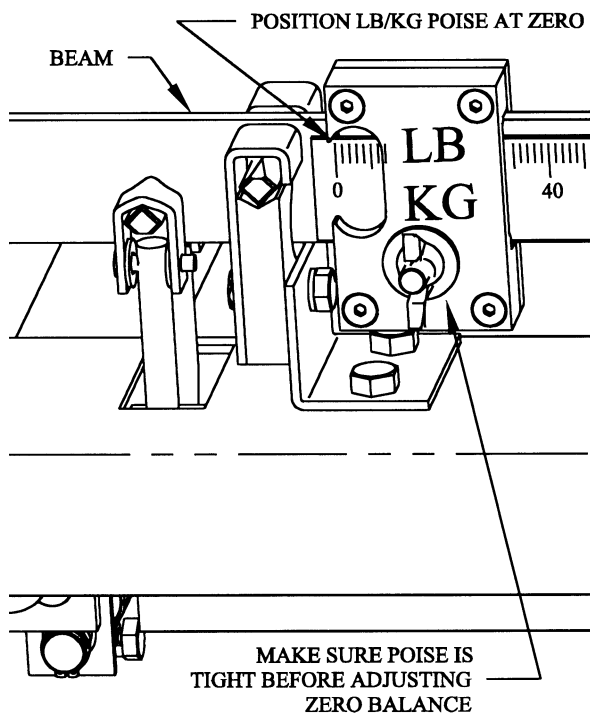

FIG. 21

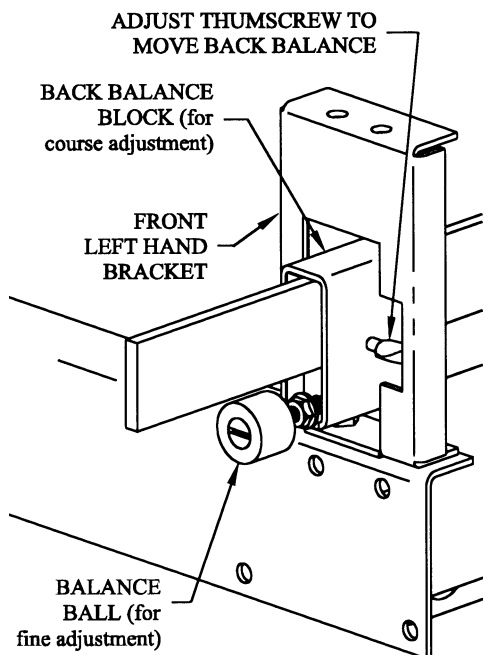

FIG. 22

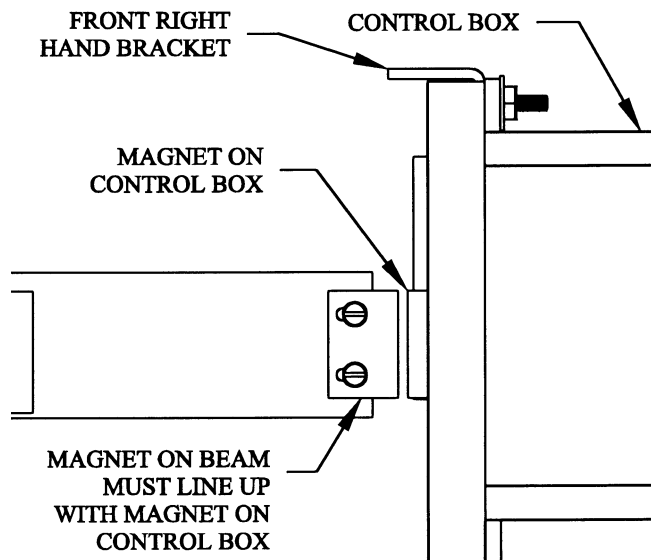

FIG. 23

STEP 17. NOTE: Make sure power is off. 220vac 20amp male and female plugs are provided on the control boxes. Wire the male plug to the power source and the female plug to the fill system motor for the rooster feeder. Turn power back on.

STEP 18. Push beam down to bottom of trig loop. Start motor for the fill system (use start switch on control box). Test switch by lifting the beam. The motor for the fill system should cut off as the beam passes the magnetic switch on the control box. See Fig. 24.

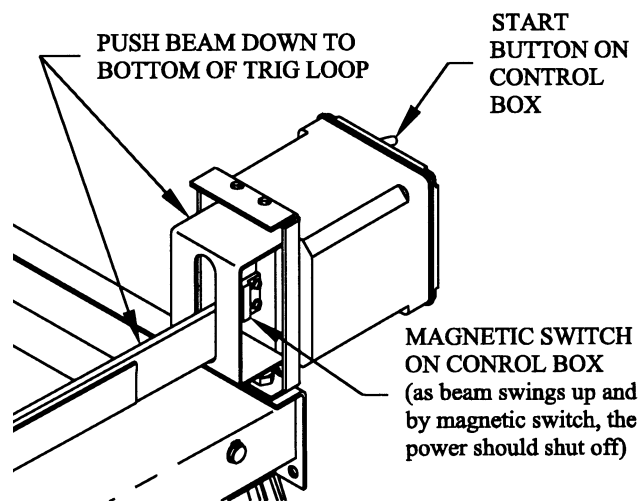

FIG. 24

STEP 19. Pull beam up to top of trig loop. Start feed line (usually done automatically by clock – or sometimes done with the start switch on the M2L control box). Test switch by pushing down on the beam. The feed line should cut off as the beam passes the magnetic switch on the control box. See Fig. 25.

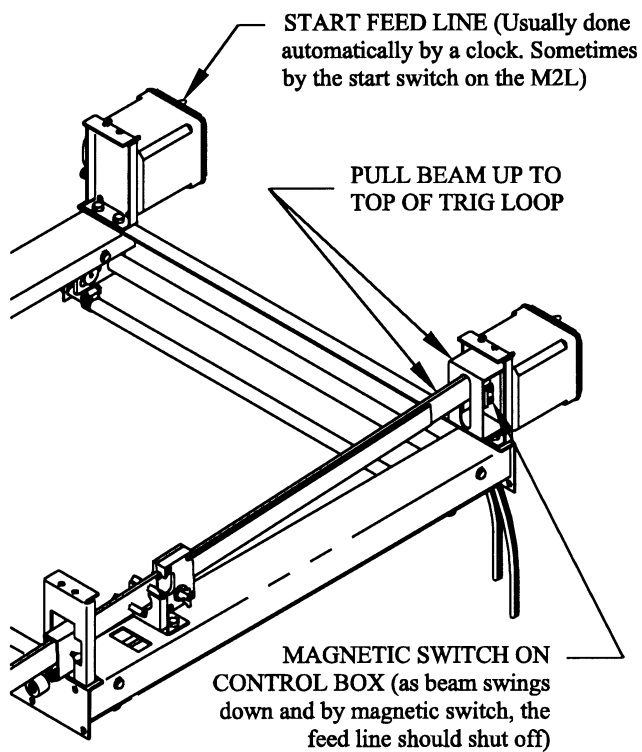
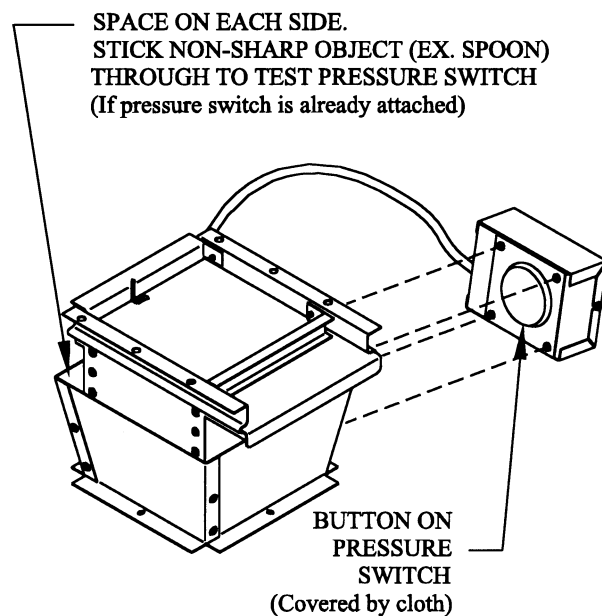

FIG. 25

STEP 20. If pressure switch was not tested before it was assembled to boot adapter, it will need to be tested now. There is space between the gate assembly and the boot adapter. The button on the pressure switch can be reached through this space. Use a non-sharp object such as a finger or the handle of a wrench to press and hold the button on the pressure switch. The feed line should start (or may have to be started manually if normally activated by clock). Release the button and the feed line should shut off. See Fig. 26.



NOTE: PARTS SHOWN UNASSEMBLED AND SEPARATE FROM REST OF SCALE FOR CLARITY.

FIG. 26

PARTS BREAKDOWN

RELAY : CUTLER HAMMER # C25BNB220B

START SWITCH : CARLING # 6FA54-78

STOP SWITCH : CARLING # 6FA58-78

MICRO SWITCH : CHERRY E5160E MODIFIED

MAGNETIC SWITCH : HAMLIN 59135-020

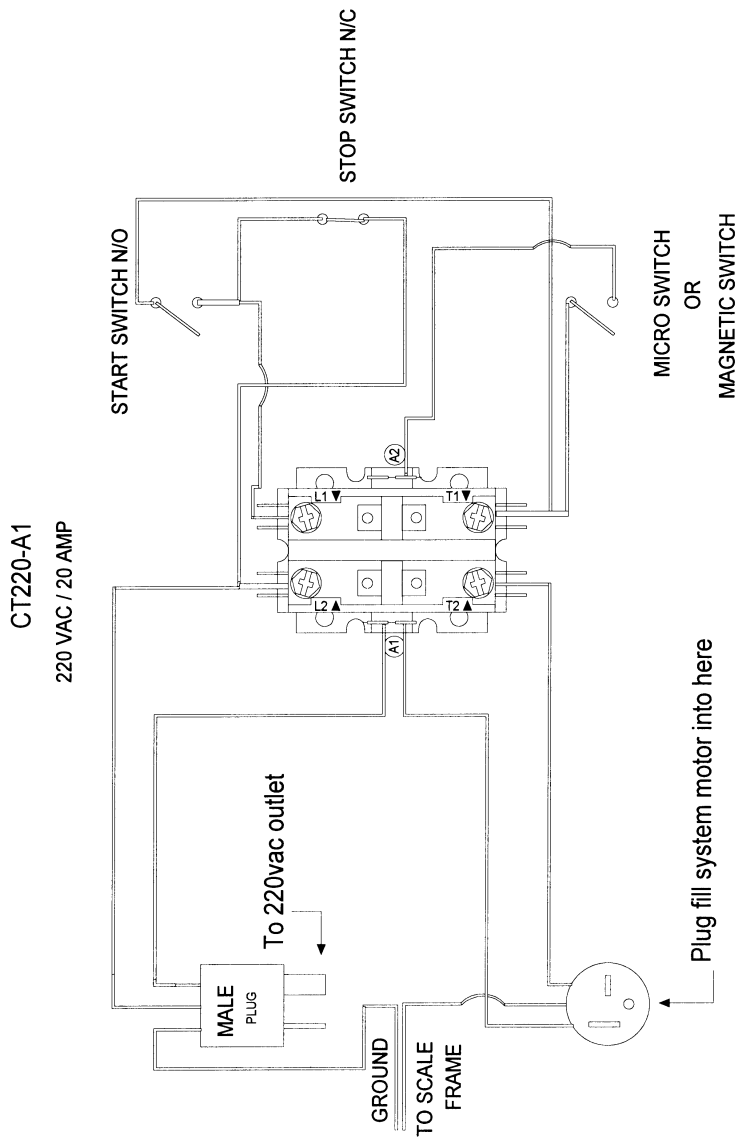

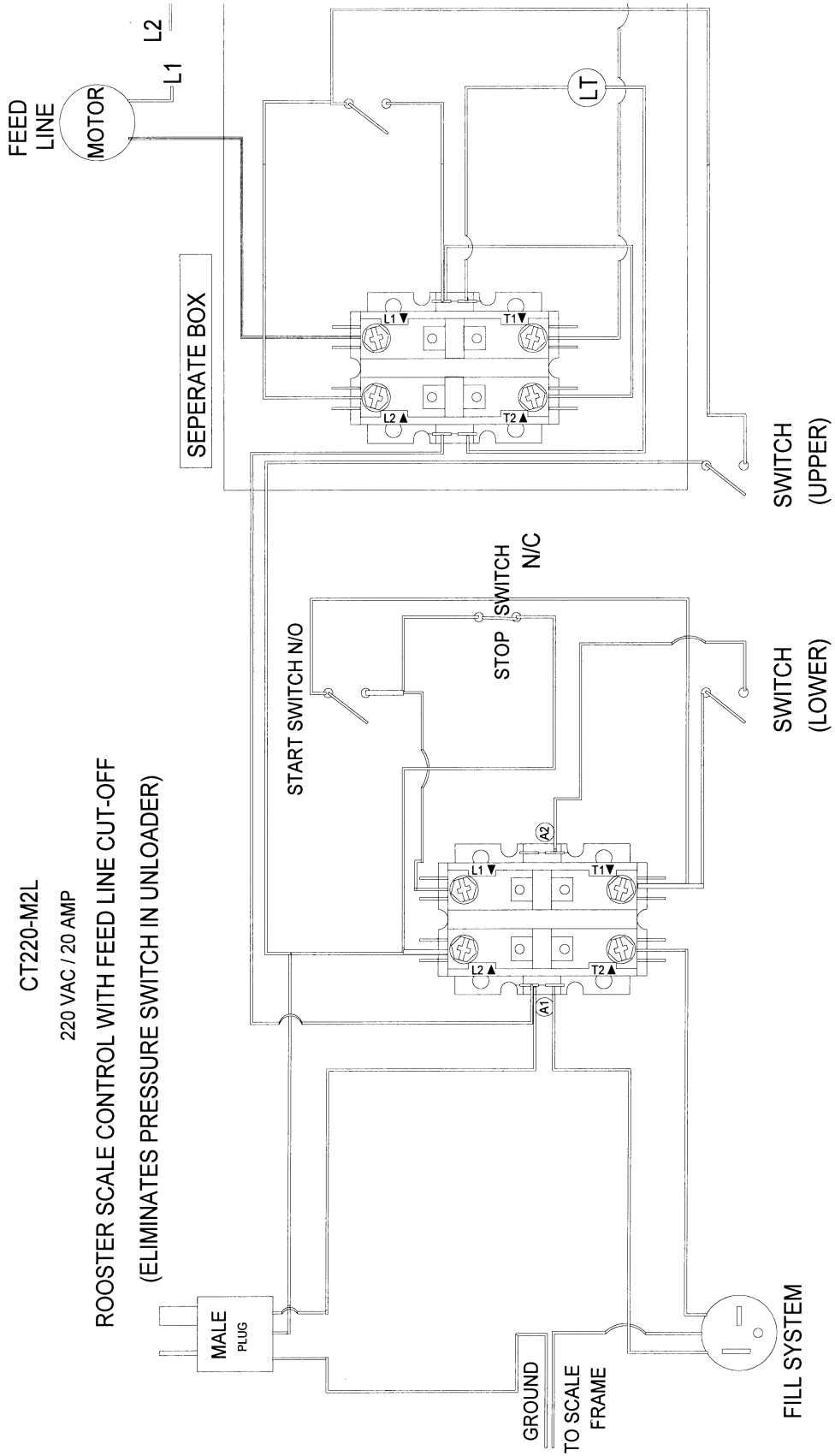

OPERATION GUIDELINES

STEP 1. Make certain gate is closed. See Fig. 1.

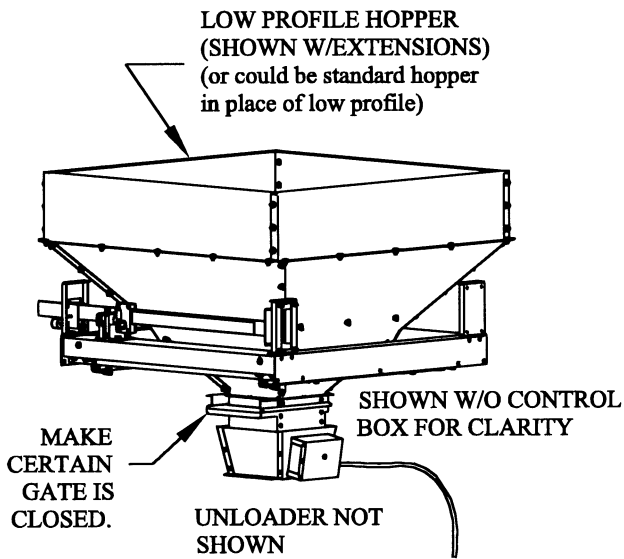

FIG. 1

STEP 2. Loosen poise on beam and slide over to desired weight. Tighten poise. See Fig. 2.

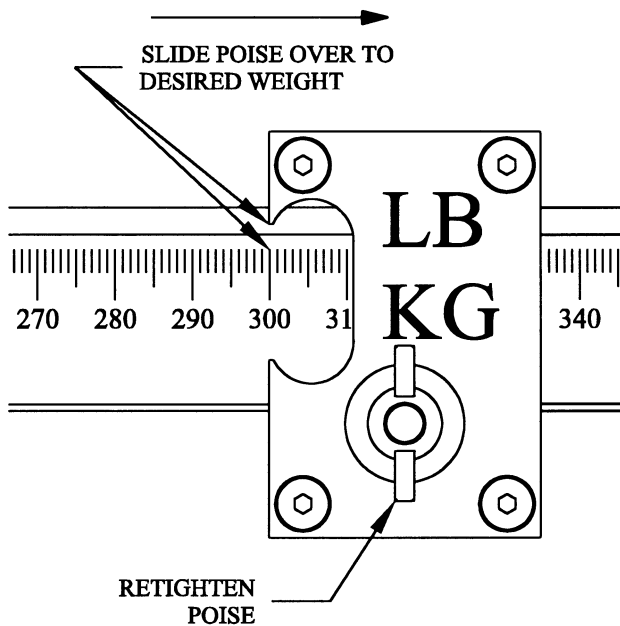

FIG. 2

STEP 3. The rooster scale uses an "M" control box (mounted on the front right hand bracket) and a pressure switch (mounted on the boot adapter) or it uses an "M2L" control box (two boxes – the second one mounted on the rear right hand bracket) and no pressure switches. For either type system, flip the start switch on the control box located on the front

right hand bracket. See Fig. 3. This will start up the fill system, which will dump feed into the hopper.

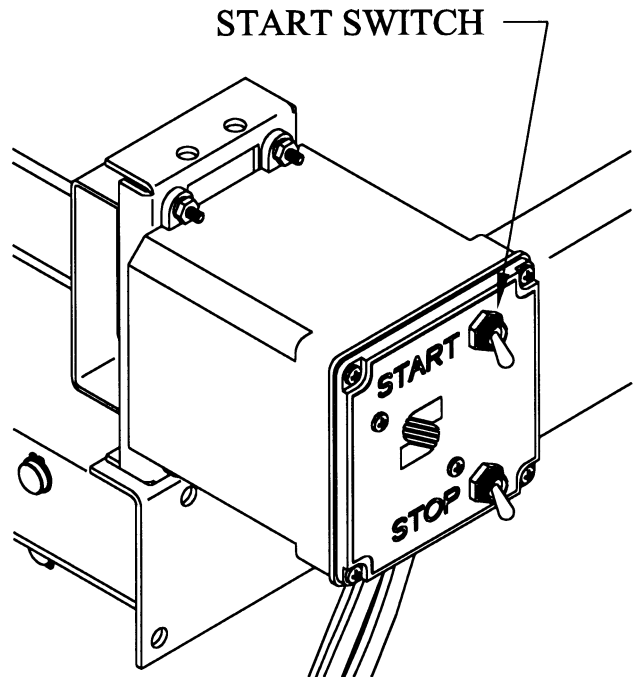

FIG. 3

STEP 4. As the hopper fills the beam will rise. When the magnet on the beam comes into alignment with the magnet on the control box (indicating the desired weight has been reached), the fill system will shut off. See Fig. 4.

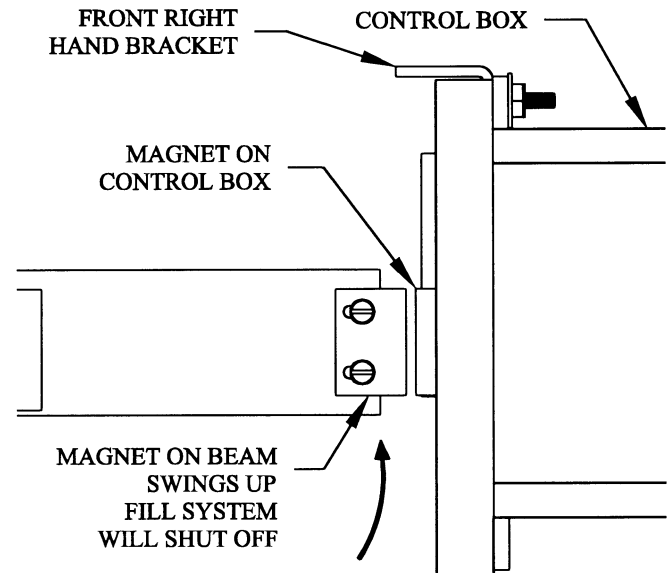

FIG. 4

STEP 5. Open the gate so that the feed can fall down into the feed line. See Fig. 5.

At this point, only a portion of the feed will fall, until the unloader is filled. The rest will fall out once the feed line is activated (usually by a clock).

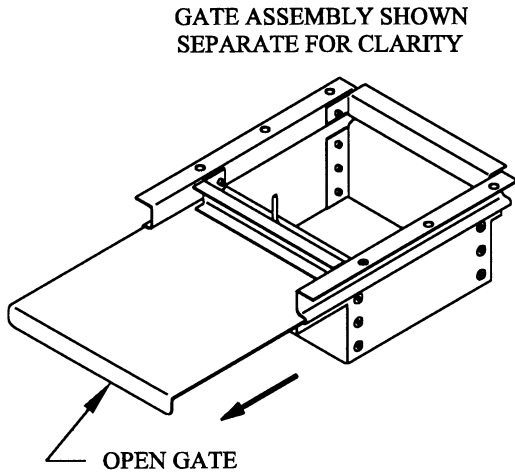

FIG. 5

STEP 6. NOTE: This step is for scales with "M" control box and pressure switch. Skip to step 7 for "M2L" control boxes (2 boxes and no pressure switch).

Start the feed line (usually started automatically by clock). The pressure switch will automatically shut off the feed line once all the feed is out of boot adapter. See Fig. 6.

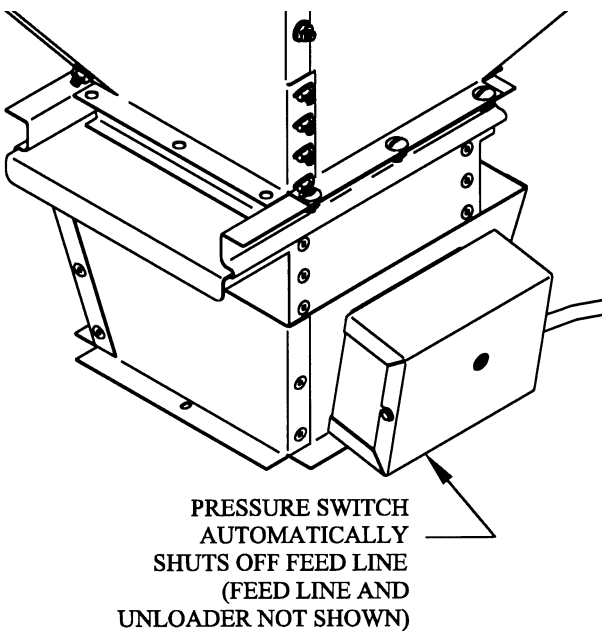

FIG. 6

Step 7. NOTE: This step for scales using the "M2L" control box. For the "M" control box with pressure switch skip to step 8.

The shut off of the feed line must be triggered by the beam. Set the LB/KG poise at zero; retighten poise. Start switch on M2L. See Fig. 7.

The beam will go up. Start the feed line (usually started automatically by clock). As the feed goes out, the beam will slowly fall until it reaches zero (magnet on beam in line with magnet on control box). A signal is sent from the control box shutting off the feed line. The poise will need to be reset to the desired weight before each filling of the hopper.

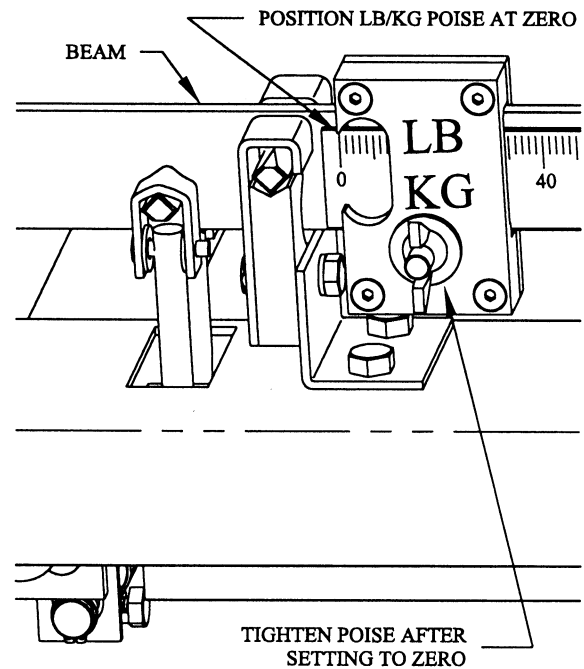

FIG. 7

STEP 8. Repeat steps 1-7 for each filling of the hopper.

TROUBLESHOOTING

The best thing about the Rooster scale is that it is nearly trouble free. The two main problems that arise with the scale are leveling, and the hanging of the shackles. So to reiterate, make certain that the scale is level. See Fig. 1.

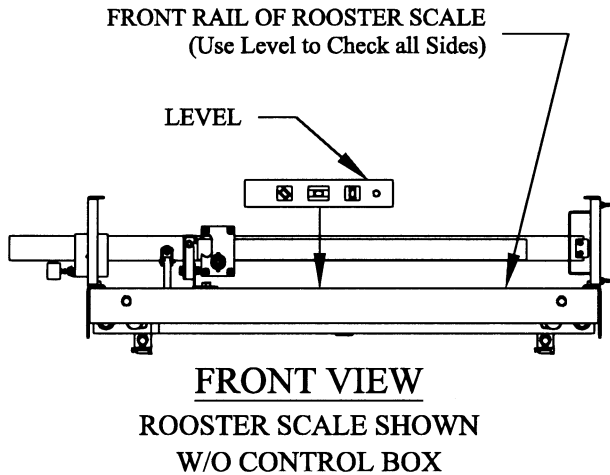

FIG. 1

Check all sides for levelness. If the scale is not level repeat step 2 from page 5 until it is level. Check all shackles to insure that they are nestled correctly in the grooves of the pins. See Fig's 2 & 3.

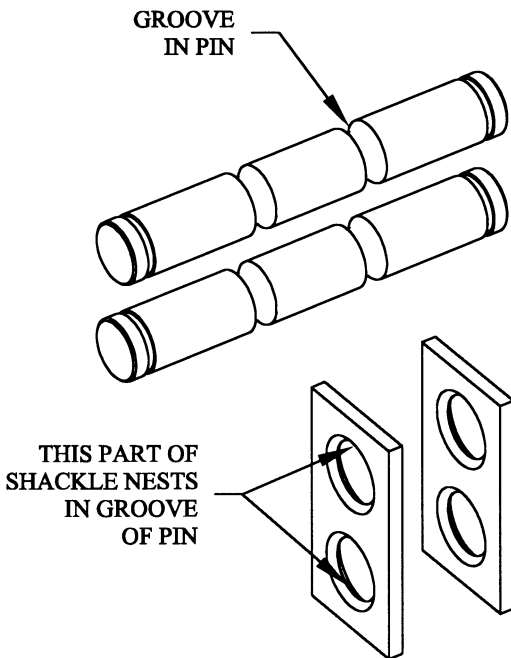
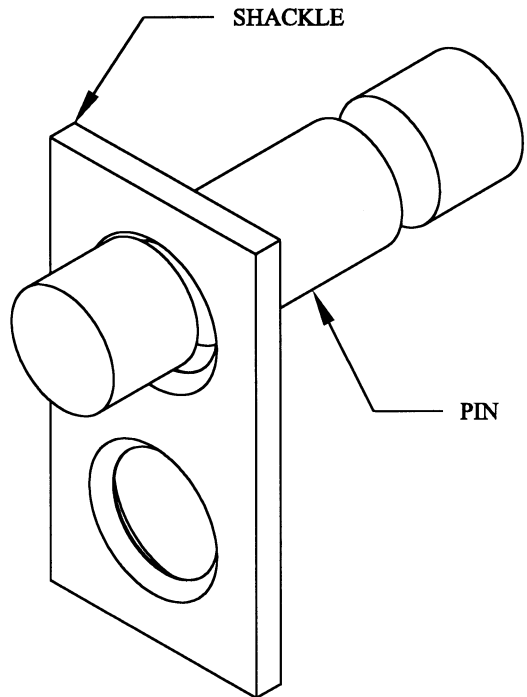

FIG. 2



THE SHACKLES SHOULD NEVER SIT ON THE SIDES OF THE PINS, BUT HANG FREELY IN THE GROOVES.

FIG. 3

The hopper should rest solely on the bars and never touch the sides of the scale. See Fig. 4.

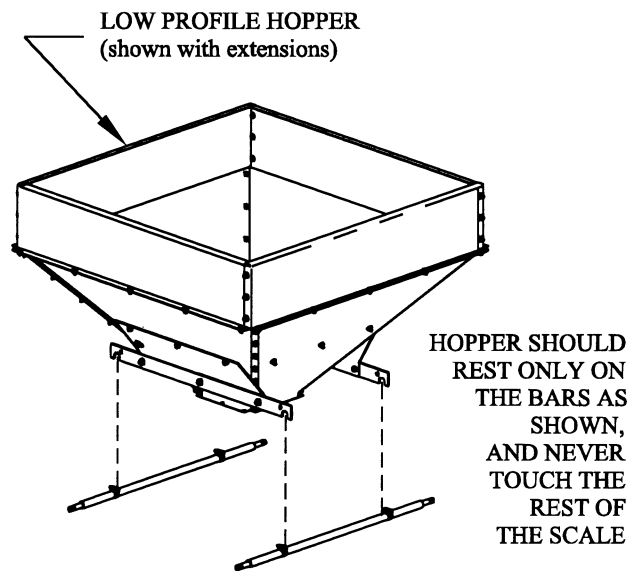

FIG. 4

600 LB ROOSTER SCALE

SUPPLEMENT SHEET (Things that are different from the other Rooster Scales)

STEP 1. After the rooster feeder is winched and cabled, you will need to find the location for the four (4) cable pulleys required to support the scale and hopper assembly. Suggested boards for support (2" x 6" min) lagged correctly into trusses. For 600 lb hoppers, eyebolts should be spaced apart 34-3/4" x 31-1/2". See Fig. 1.

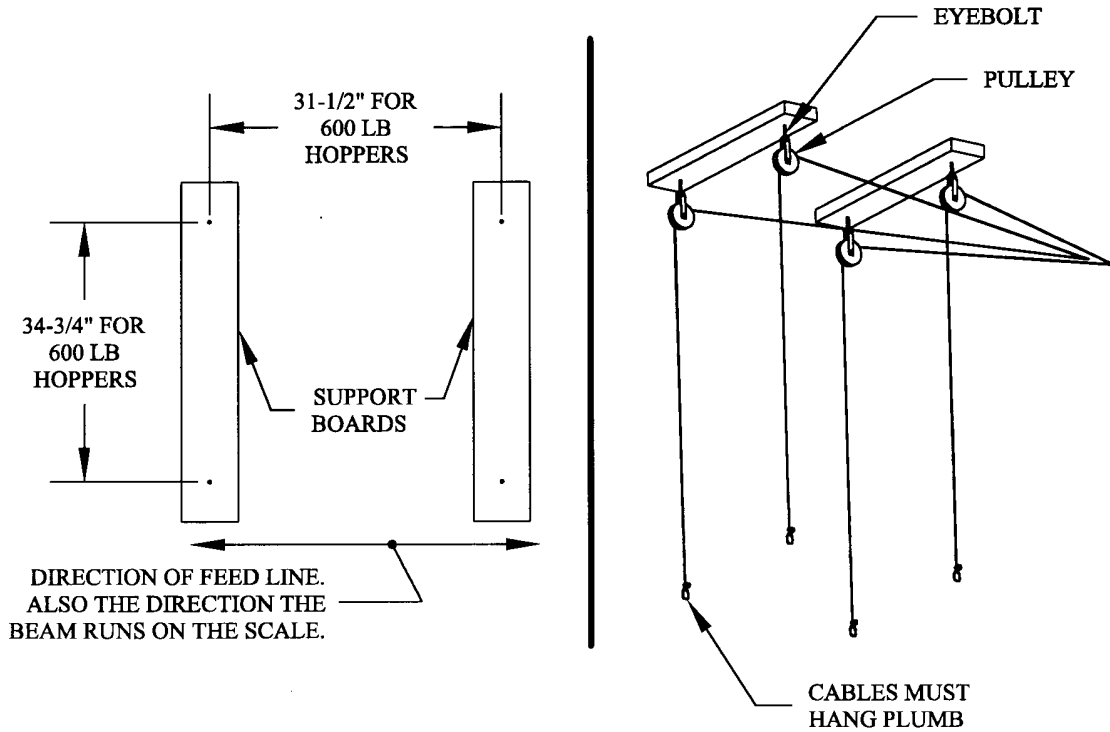

FIG. 1

STEP 2. Attach cables to scale between 1/2" washers using 1/2" bolts and nuts at each corner. See Fig. 2.

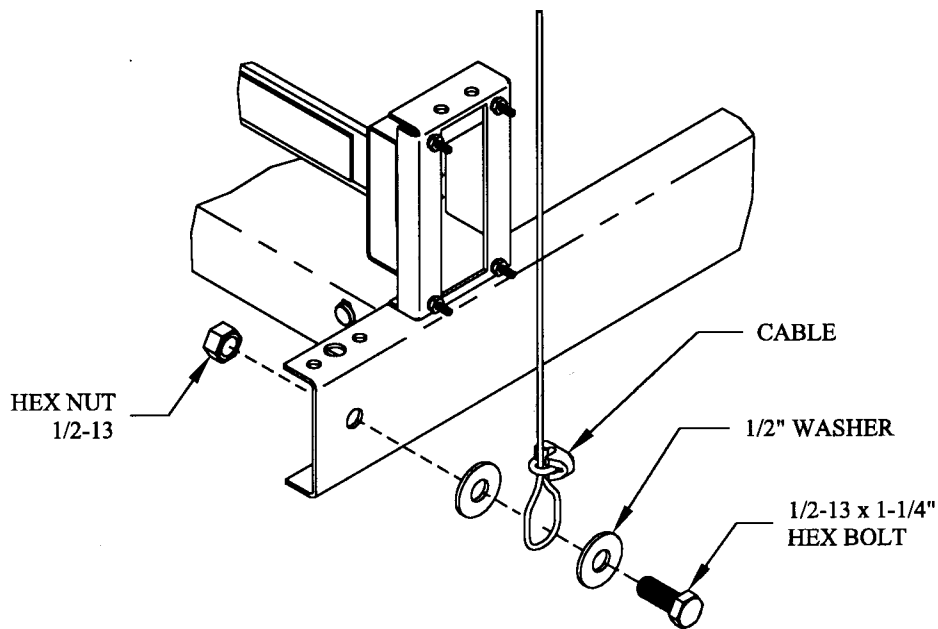
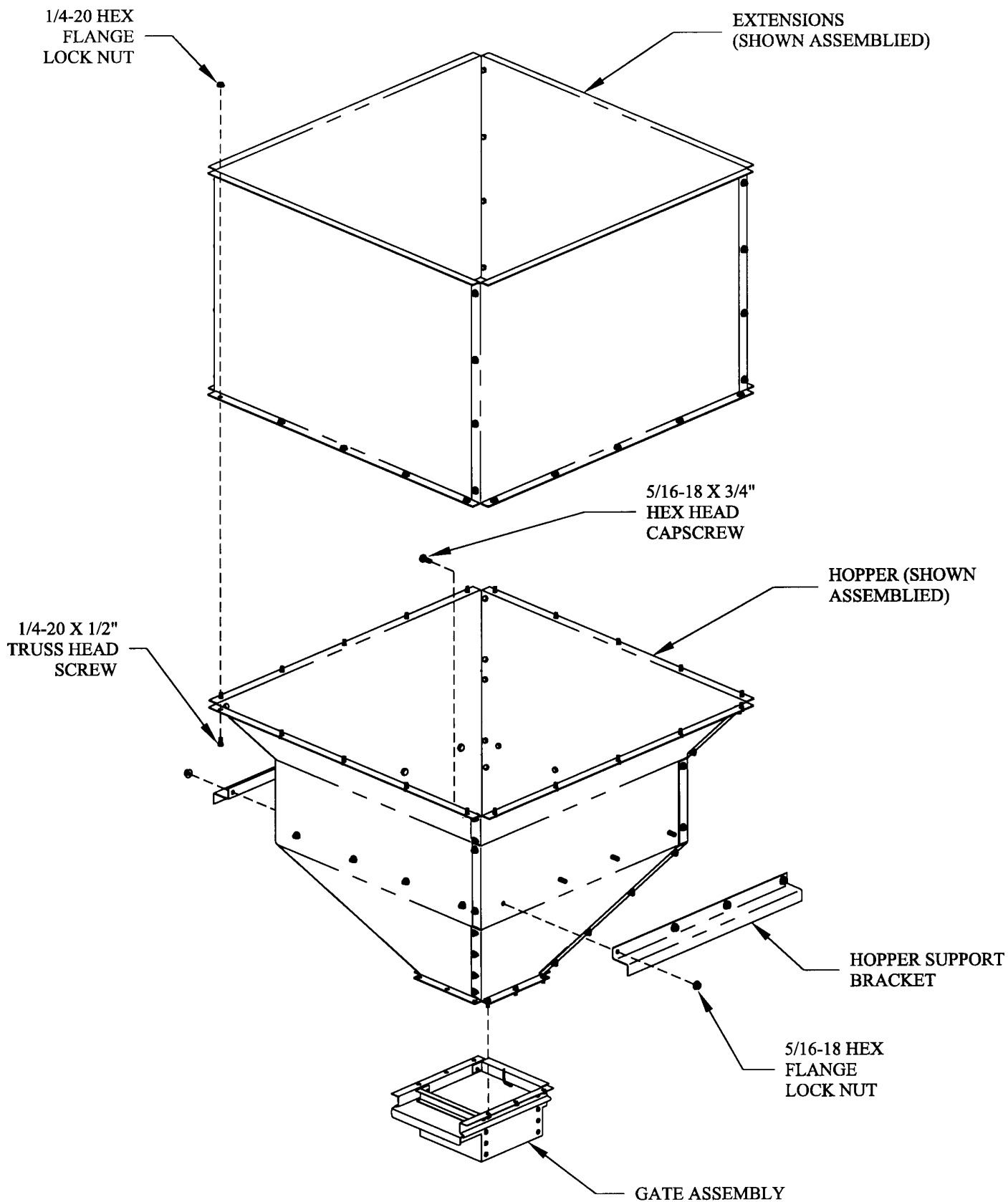

FIG. 2

STEP 3. Assemble hopper kit as shown. See Fig. 3.

600 LB. HOPPER KIT



SPINKS SCALES

INSTRUCTION/OPERATOR'S MANUAL

For

ROOSTER

SCALES

MODELS:

250 #

350 #

600 #

