

# SPINKS SCALES

INSTRUCTIONS/OPERATIONS MANUAL

For  
**BIN SCALES**  
**MODELS:**

**5,000 #**  
**10,000 #**

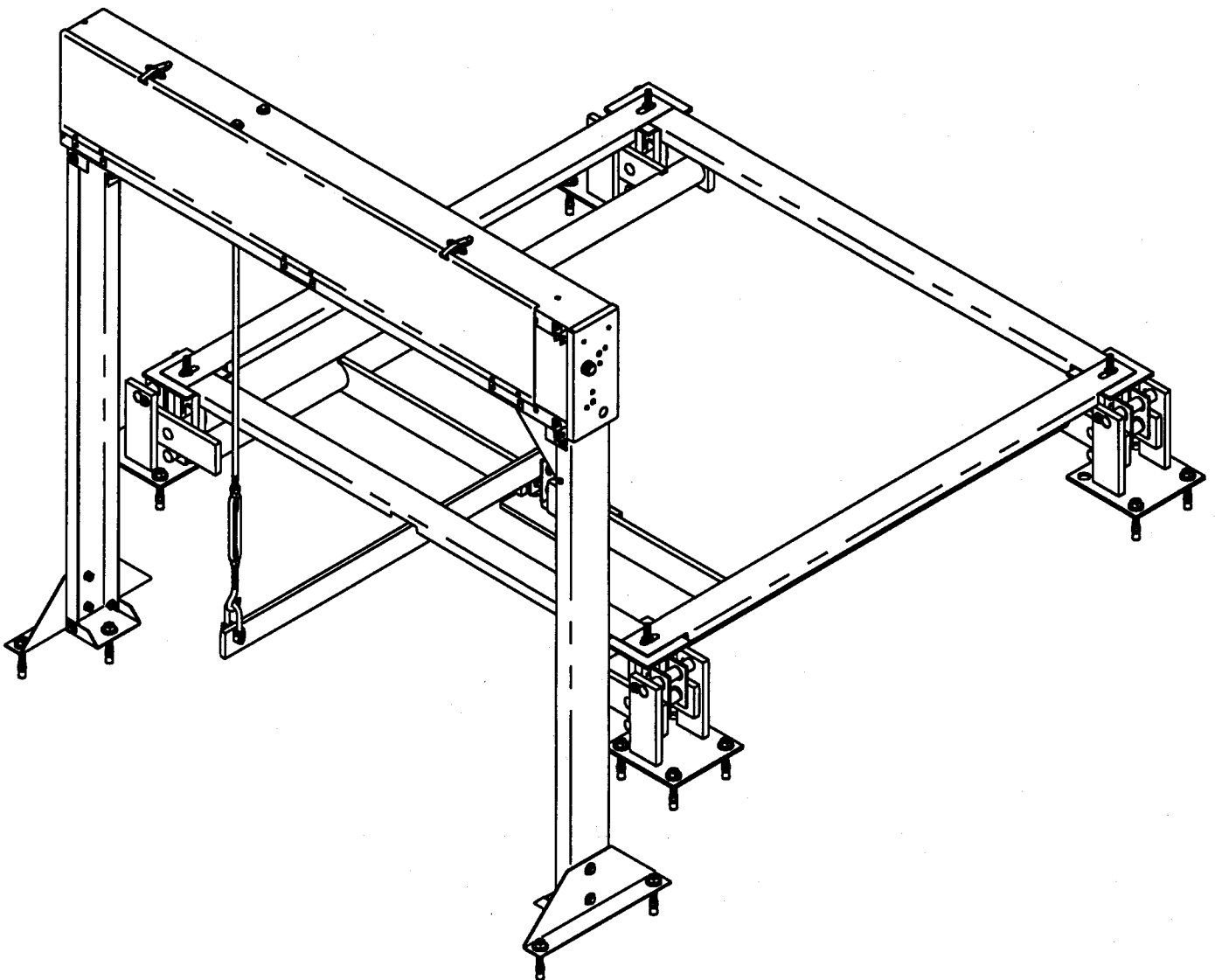

FEBRUARY, 2000

TABLE OF CONTENTS

CONCRETE PLACEMENT .....Page 3

LAYING OUT LEVERS.....Pages 4-6

BEAM BOX INSTALLATION ..... Page 6-7

BEAM INSTALLATION..... Page 7-8

BIN SET-UP .....Pages 9-11

LEVEL STEELYARD ROD.....Page 12

SHACKLE/LEVER CHECK..... Page 13-15

SECURE SCALE.....Page 15

BEAM/MOUSEGUARD CHECK.....Page 16

BIN SHIM FIX .....Page 17

CALIBRATION ..... Page 18-22

TERMINAL STRIP WIRING .....Page 23

DAILY OPERATION ..... Page 24-26

# BIN SCALE INSTALLATION GUIDELINES

Note: Special tools needed to install scales: hammer drill and a rubber hammer. Take some time to install the scale. A properly installed scale almost never requires service!

Step 1. Before beginning, check that the concrete slabs are level. The weigh bin should be 8-10 feet from the house. The fill bin should be 15 feet from the weigh bin. See Fig. 1.

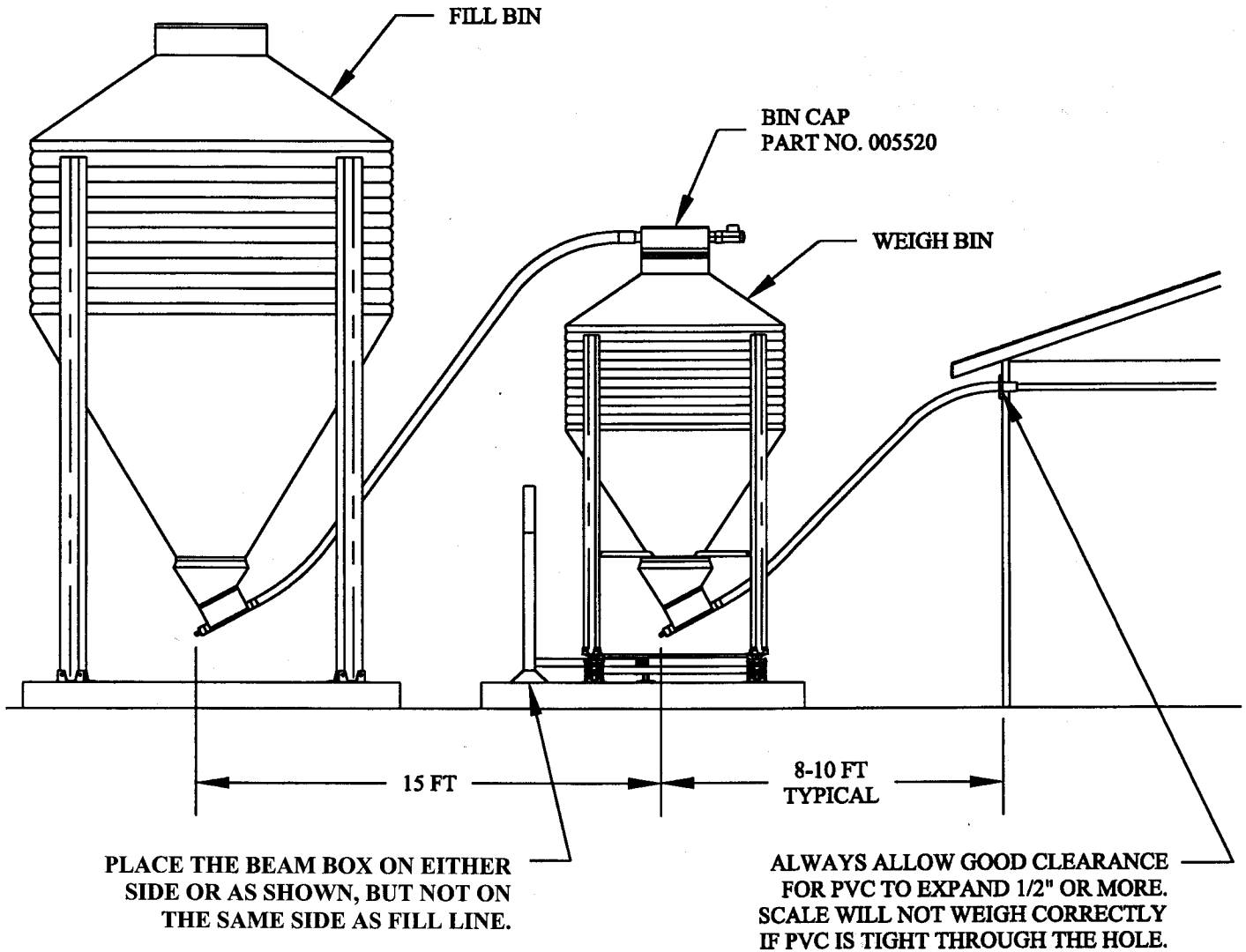

FIG. 1

STEP 2. Lay the pre-assembled lever systems out on the concrete pad. See Fig. 2. Make certain transverse lever is in correct position and not rotated 180 degrees the wrong way about the pivot.

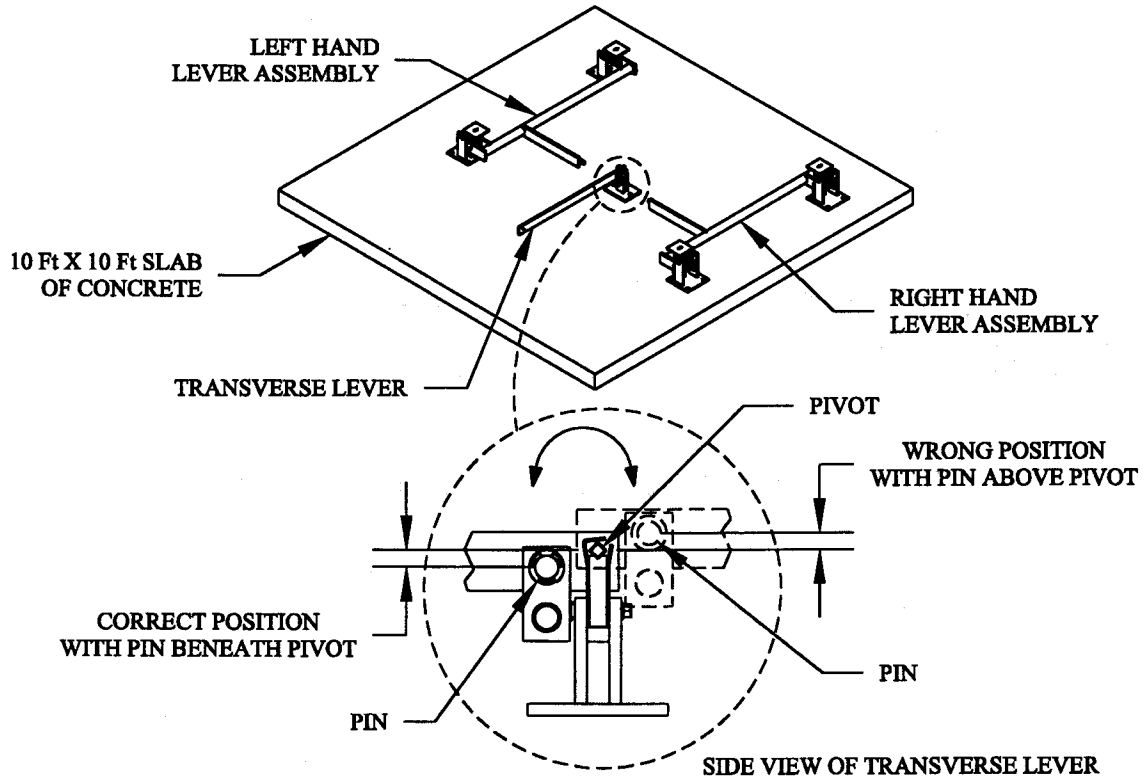

FIG. 2

STEP 3. On a 10 ft x 10 ft concrete slab (assuming that is the size that was poured) the Right Hand Lever Assembly can be positioned approximately 30"-33" and 15"-20" from the back right corner of slab. See Fig 3.

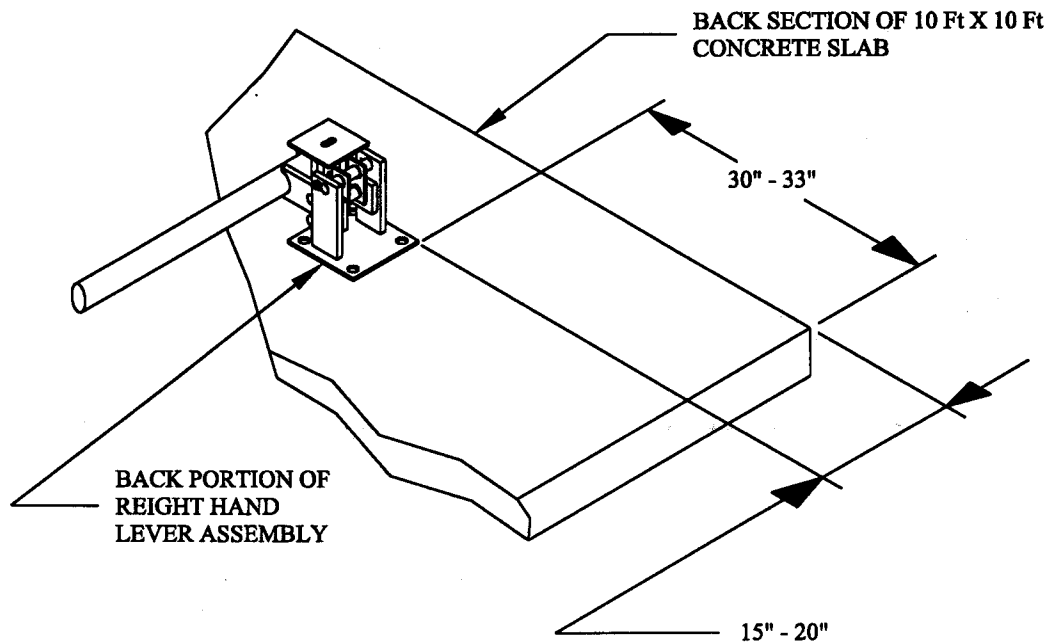
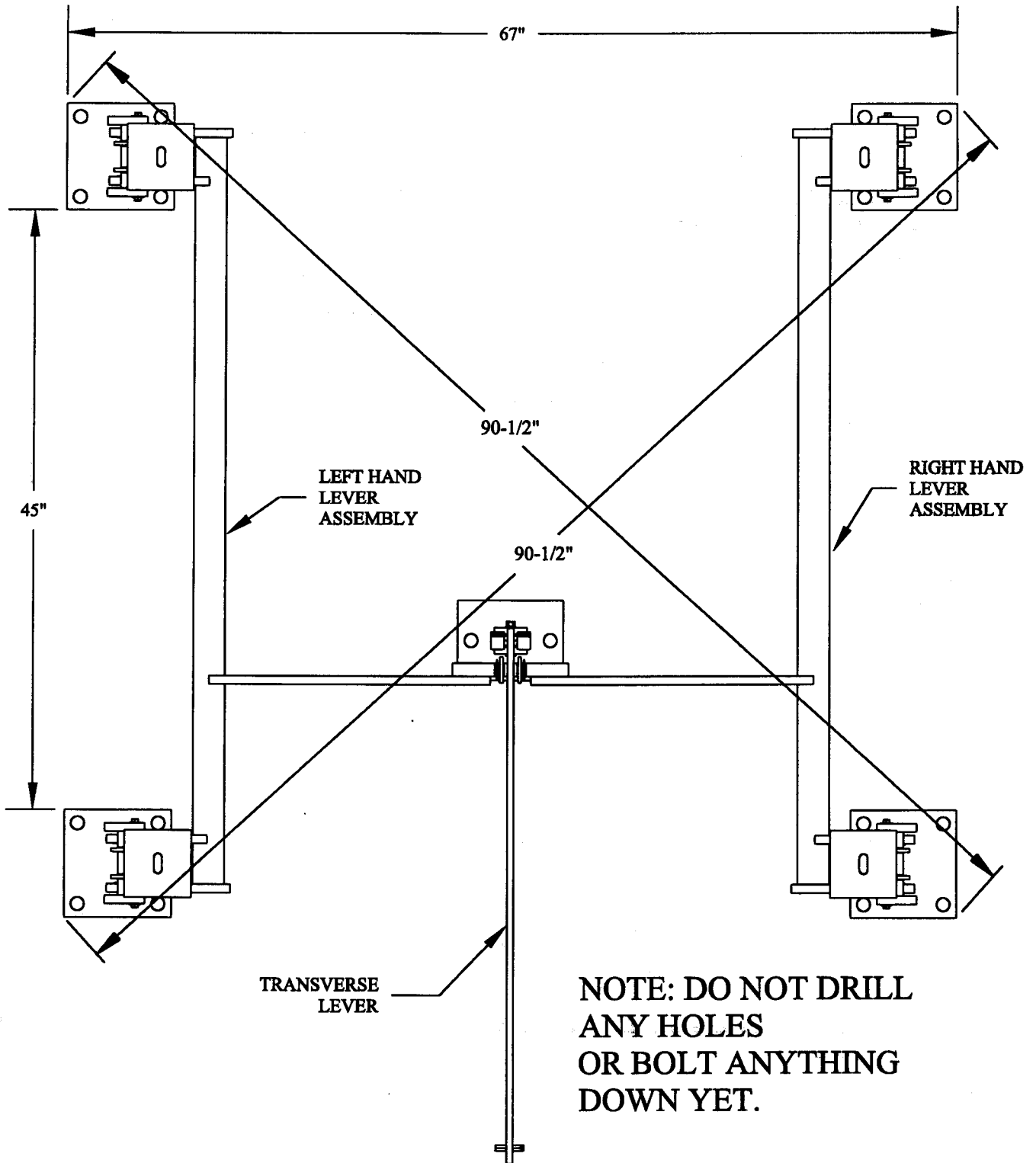

FIG 3

Step 4. Position the rest of the lever system, being mindful to use all the dimensions including both diagonal dimensions so that the scale will be square. See Fig. 4.

**TOP VIEW**



**FIG 4**

STEP 5. Line up the transverse lever assembly with the front section of the right and left hand lever assembly. See Fig 5.

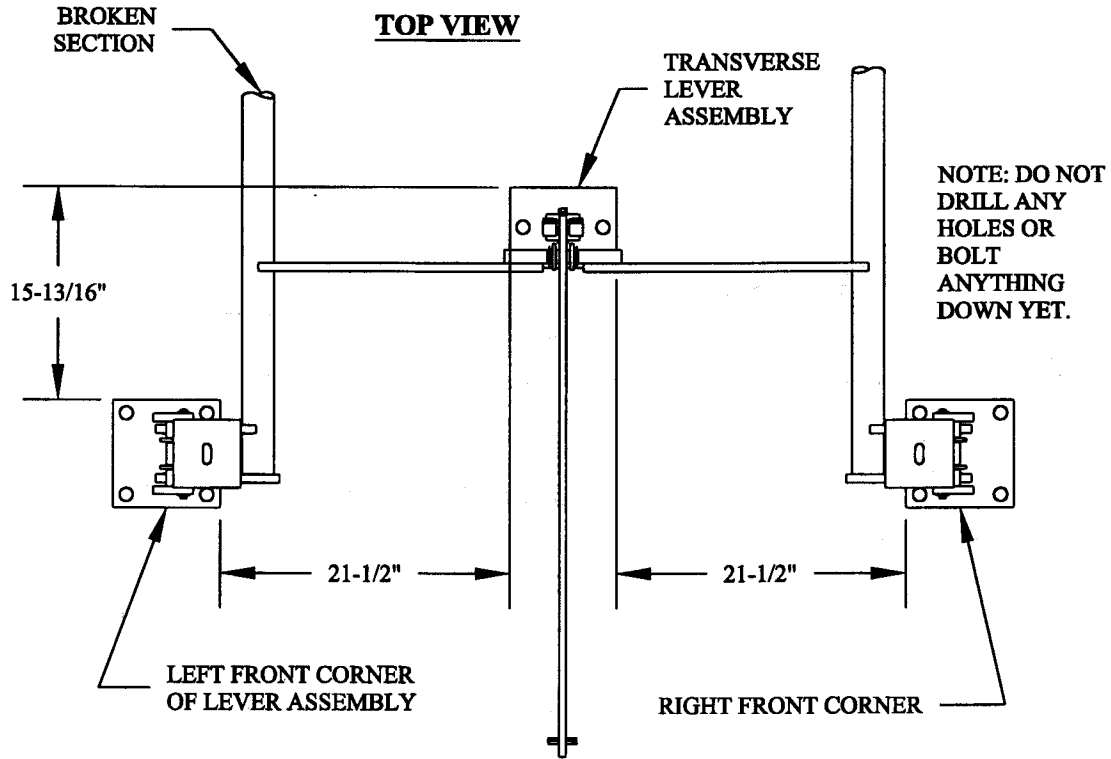

FIG. 5

STEP 6. Secure the beam box legs (2, one on each end) to the bottom of the beam box. Use 3/8" bolt (2), washers, lock washers and nuts. Secure triangular gusset with 1/4" truss bolts (2) and hex flange nuts. See Fig. 6A. Fasten the gusset to the bottom of the beam box legs using 3/8" hardware. See Fig. 6B. Tighten securely.

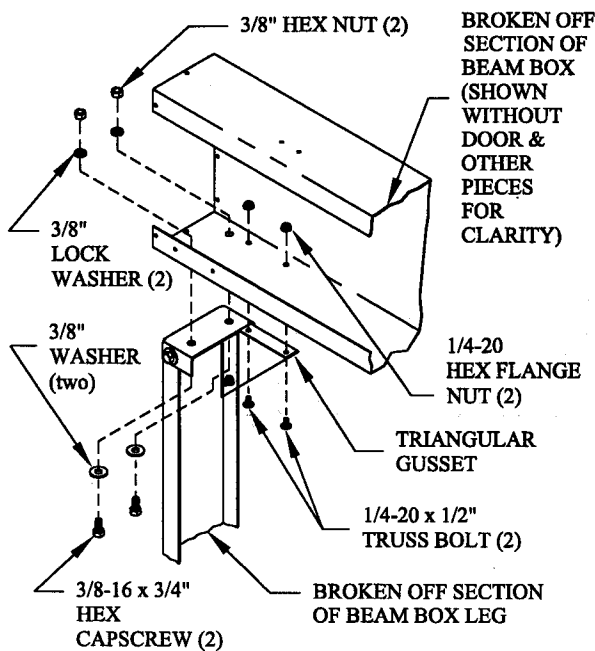

FIG. 6A

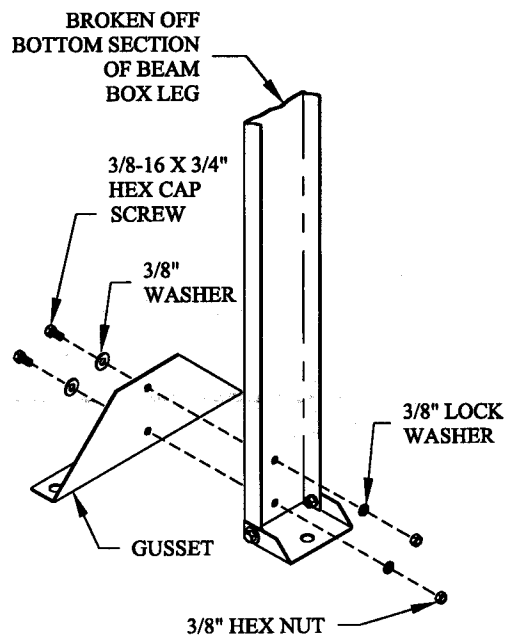
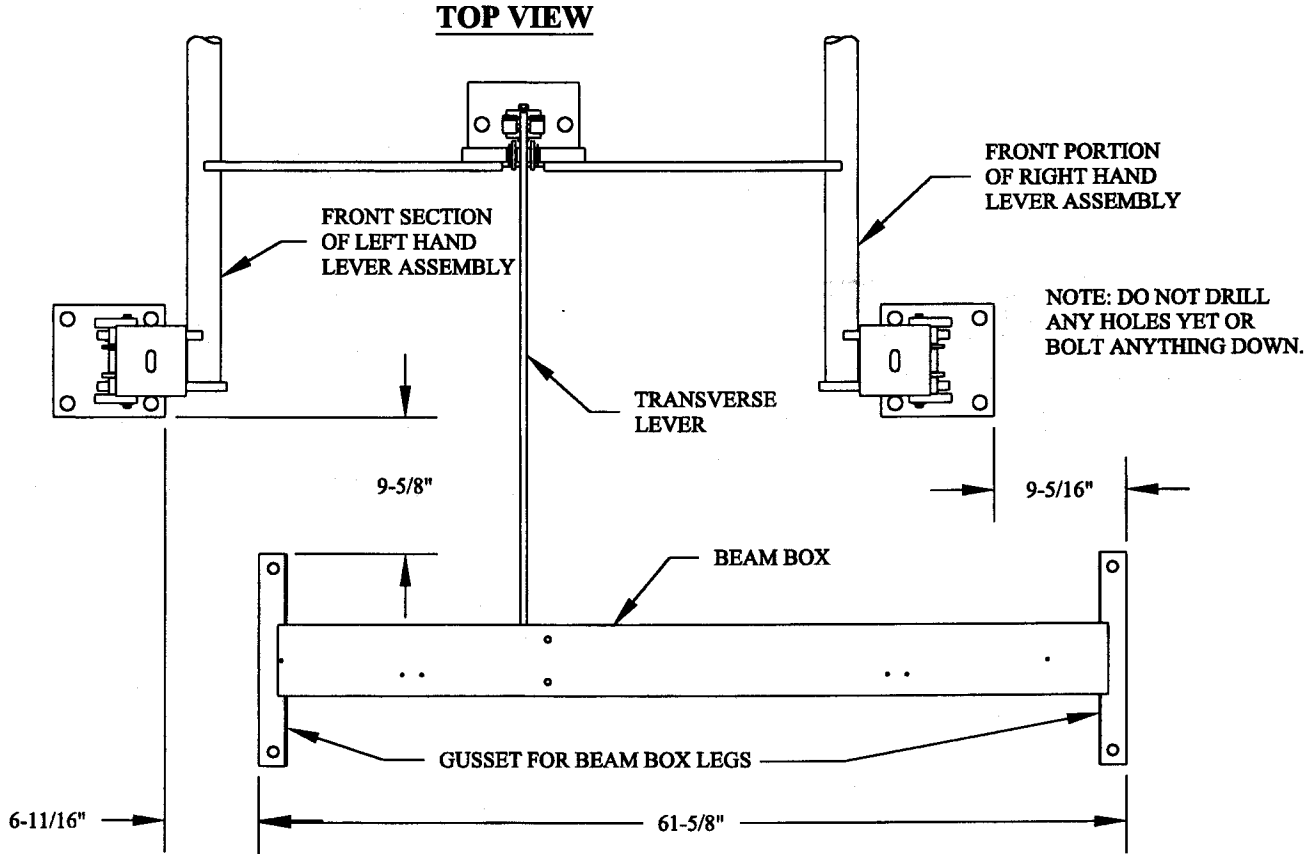
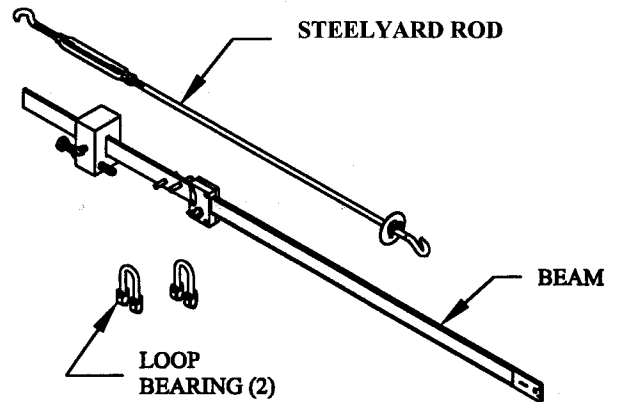
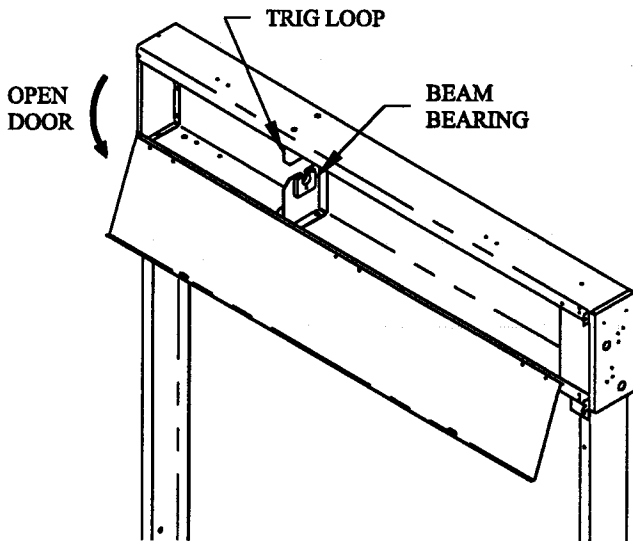

FIG. 6B

STEP 7. Place the gussets (now attached to the beam box legs) so they are properly positioned with the lever assembly. See Fig. 7.



STEP 8. Open the door on the beam box. Notice where the trig loop and beam bearing are; the beam will be placed here. Remove the steelyard rod, beam and loop bearings (2) from the box. See Fig's. 8A & 8B.



STEP 9. Reach through trig loop with fingers and push whiskers up and down so that they are out of the way. While holding the whiskers, slide beam through trig loop. See Fig 9A. Place the front pivot on the beam so that it pivots in the center of the beam bearing. See Fig. 9B. Slip the loop bearing over the back pivot on both the front and backside of the beam. See Fig. 9C. From underneath the beam box, push the steelyard rod up through the big hole (in the beam box) and hook it into the loop bearing. Use the end of the steelyard rod with the mouseguard. See Fig. 9C.

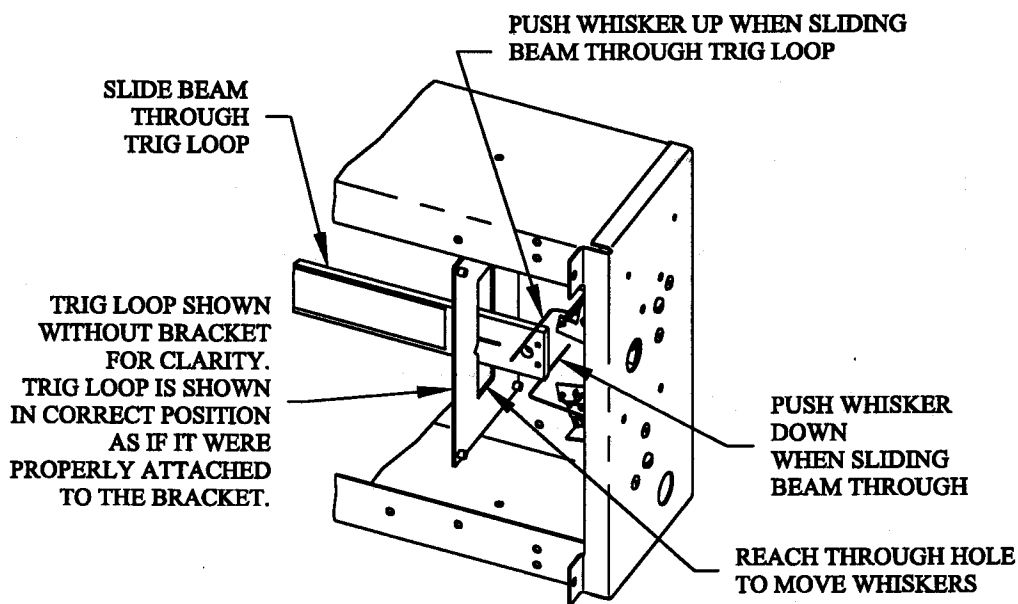

FIG. 9A

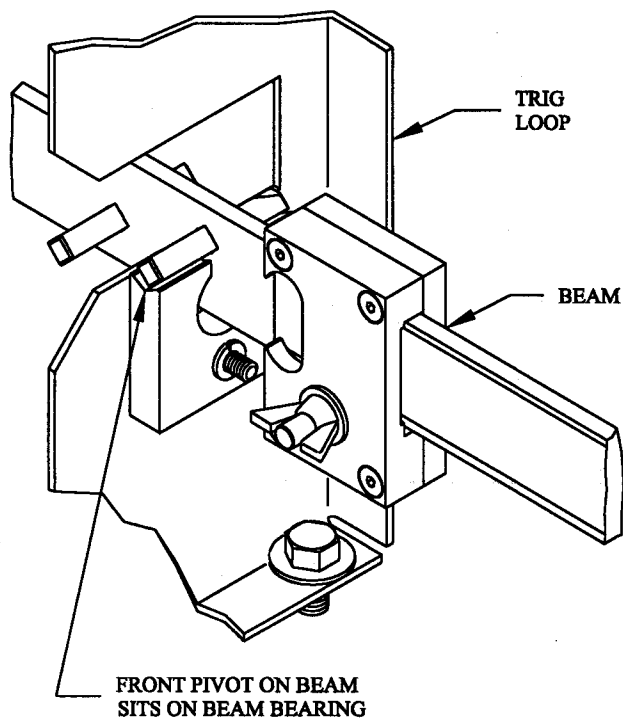

FIG. 9B

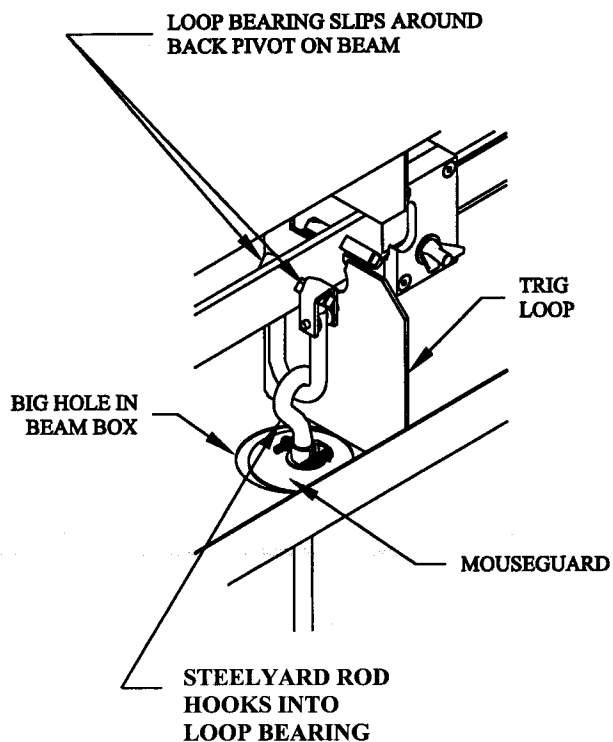

FIG. 9C



STEP 10. Place the stabilizer brackets over the four corners of the lever assembly. Be sure to place the slotted bracket in front so that it fits over the front lever. See Fig. 10A. Locate the hardware bag found in the hardware box. In each corner, slide the bolt 1/2-13 x 2" through the washer and up through the plate and brackets. Secure with retaining ring at four corners. See Fig. 10B.

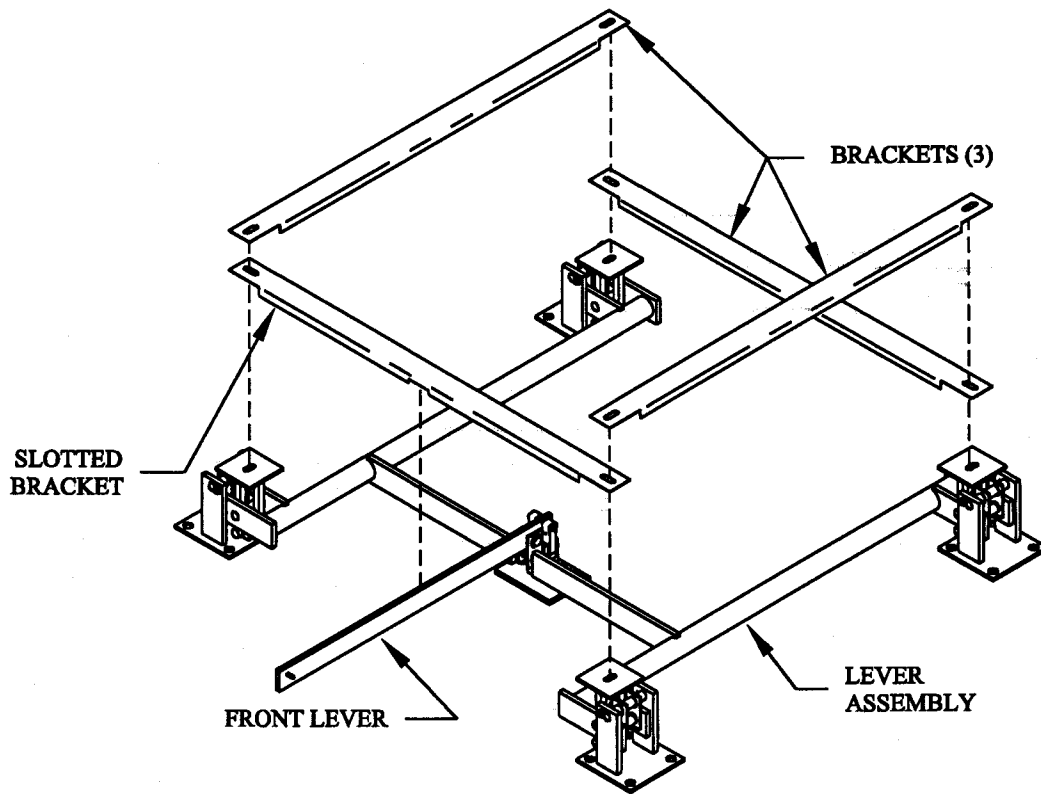

FIG. 10A

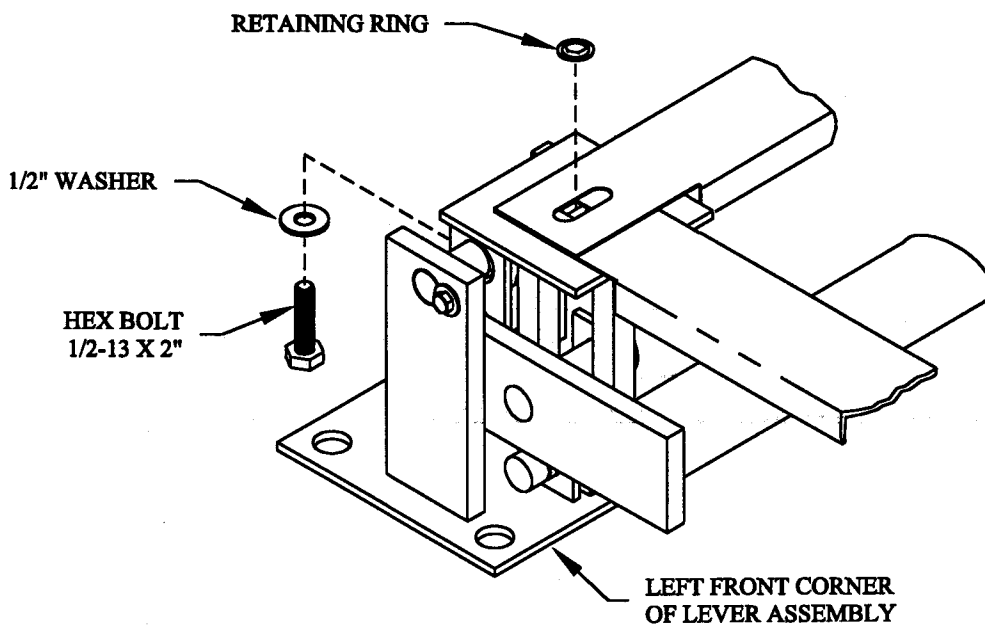

FIG. 10B

STEP 11. Place the four bin legs over the hex bolt on the four corners of the lever assembly. See Fig. 11A. Fasten all four bin legs with 1/2" washer, lock washer and hex nut 1/2-13. See Fig. 11B.

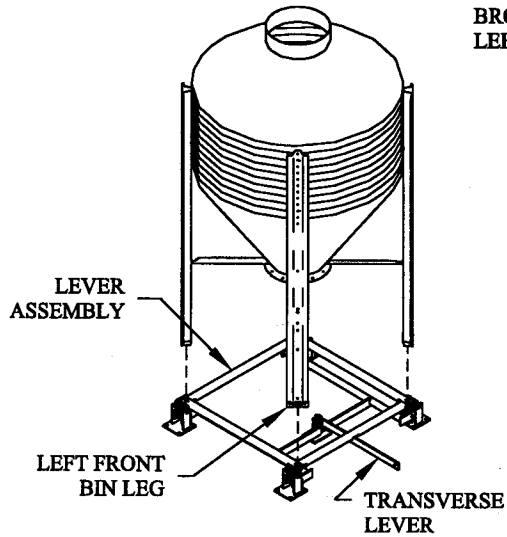
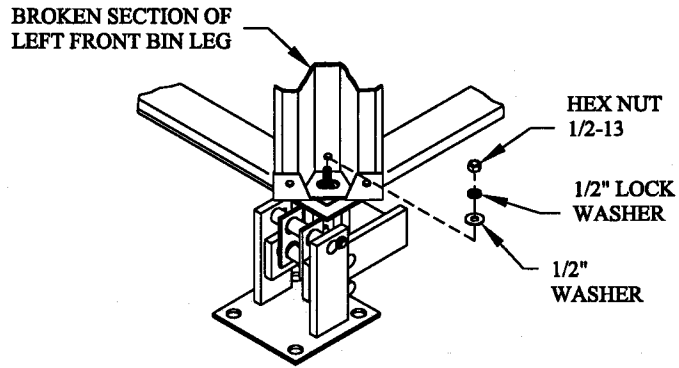

FIG. 11A



FASTEN ALL FOUR BIN LEG CORNERS

FIG. 11B

STEP 12A. The position of the scale may change when the fill system is attached. In order to limit the displacement of the scale, drill a hole in the concrete through the outermost hole in each bottom plate. Then drop a rod or the anchor bolts (supplied) into the holes. Do not tighten anything down yet. See Fig. 12A. Attach the bin cap and transition to the bin and connect all fill systems, augers and motors. Remember to allow clearance for pvc to expand. Scale will not weigh correctly if pvc is tight through the hole in the house.

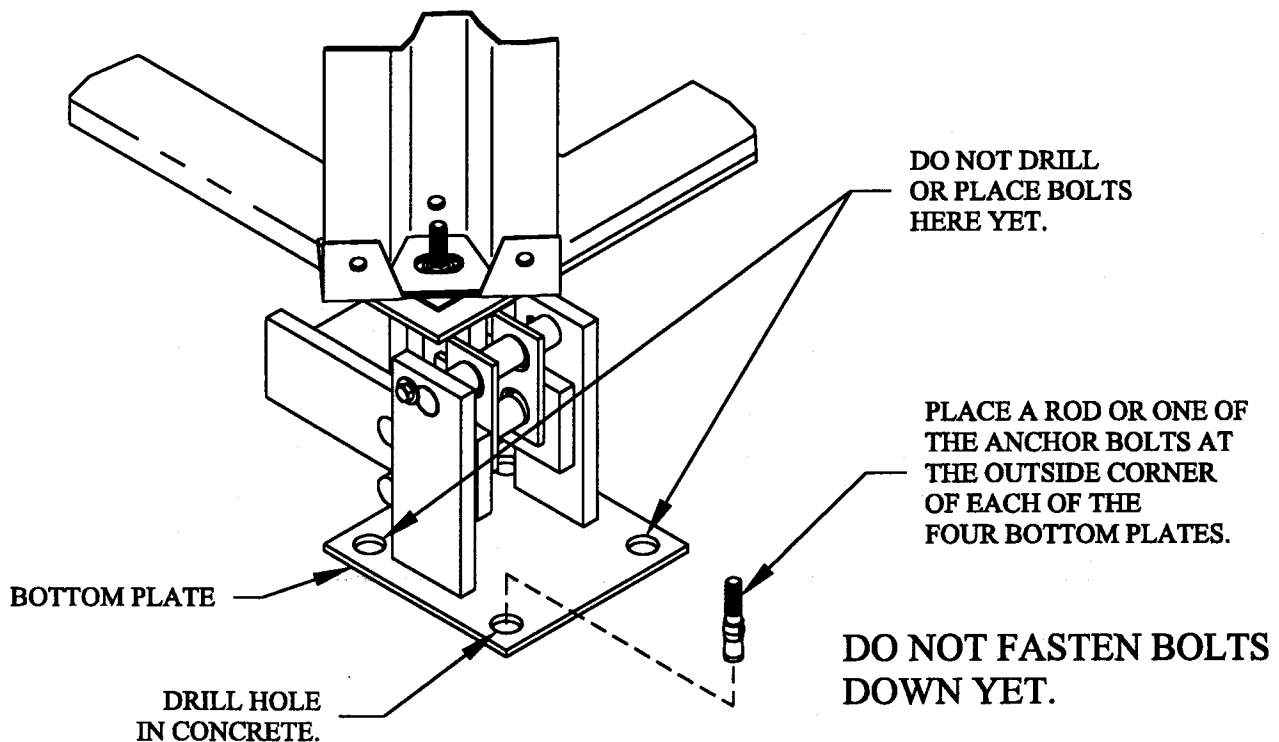

FIG. 12A

STEP 12B. After the fill system is installed, be sure to check that the square bars are not rubbing against the pins. See Fig's. 12B & 12C. If they are rubbing, loosen the bolt that holds the bin to the top mounting plate, shift the top mounting plate so that there is about 1/4" clearance.

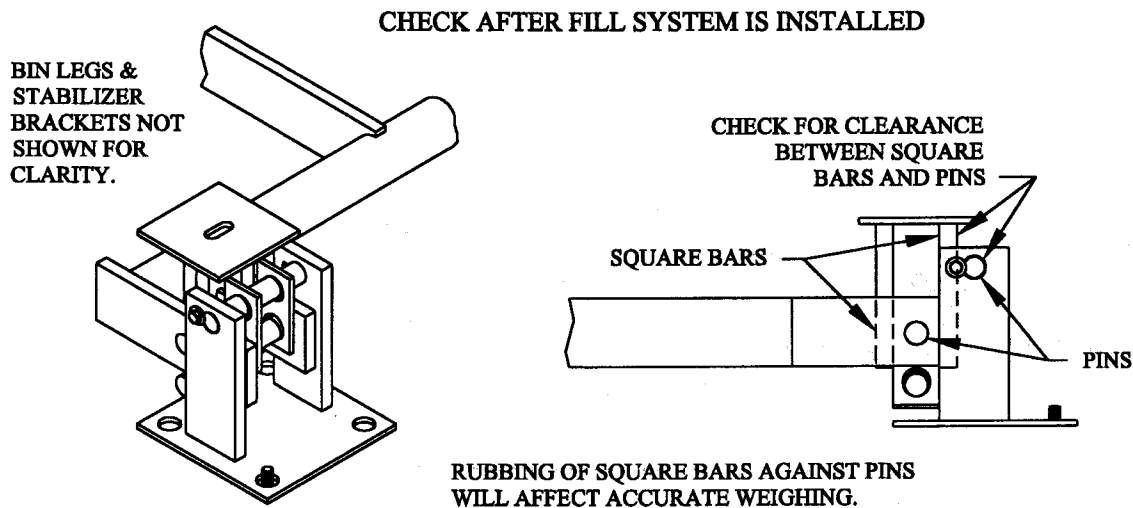

FIG. 12B

**WRONG!!**

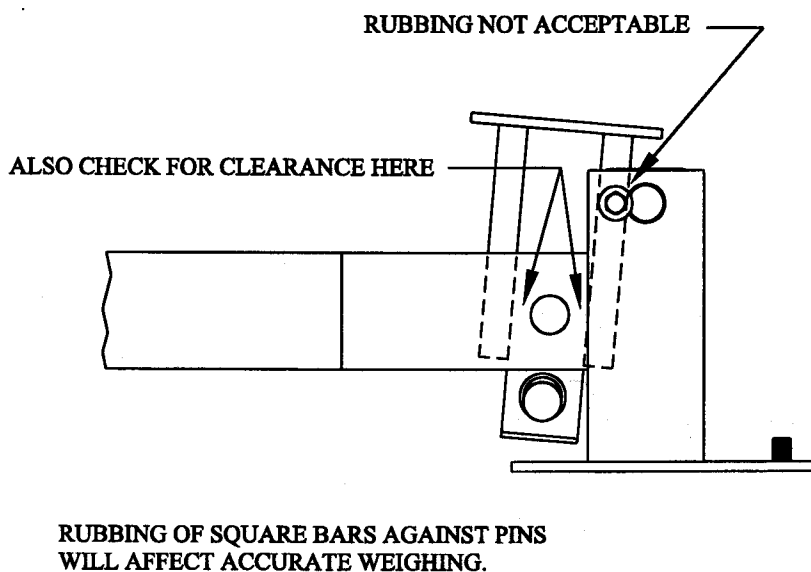

FIG. 12C

STEP 13. Place a level on the side of the steelyard rod. If it is not level, tap the legs in or out until the steelyard rod is level. See Fig. 13.

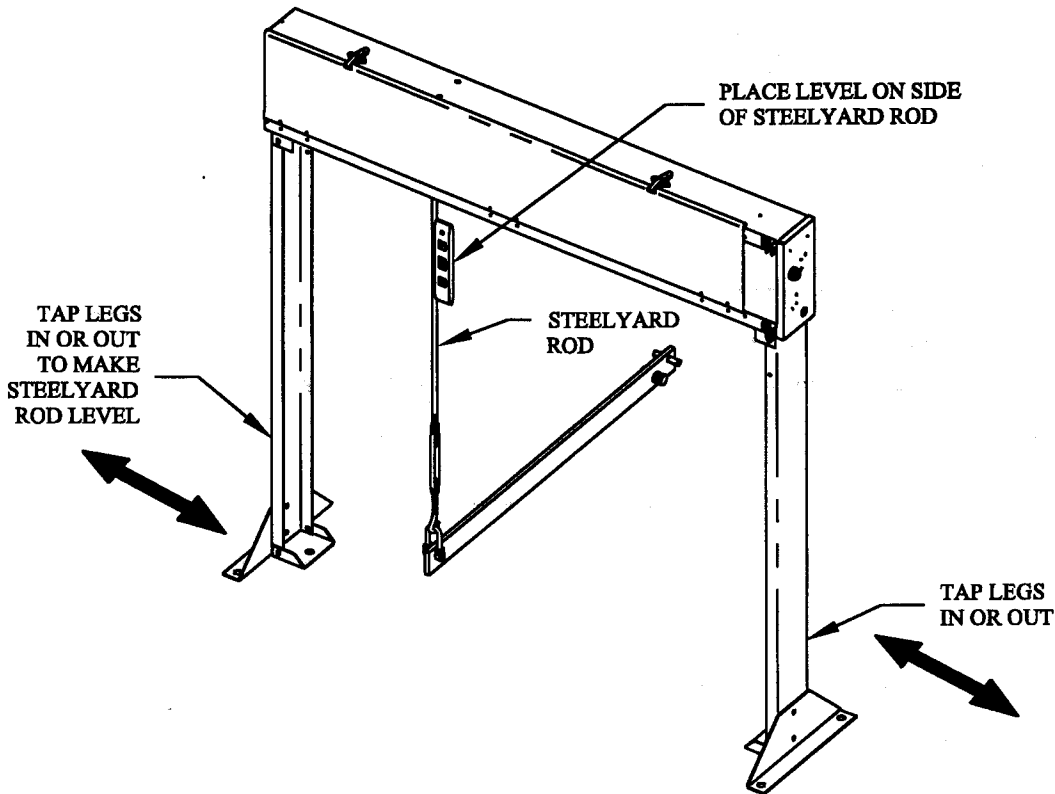

FIG. 13

Step 14. Place level on front of steelyard rod. If it is not level, tap the legs front or backwards until the steelyard rod is level. See Fig. 14A. Move level to top of transverse lever arm. If it is not level, loosen nuts, then adjust turnbuckle to move steelyard rod up or down as needed. Tighten nuts securely. See Fig. 14B.

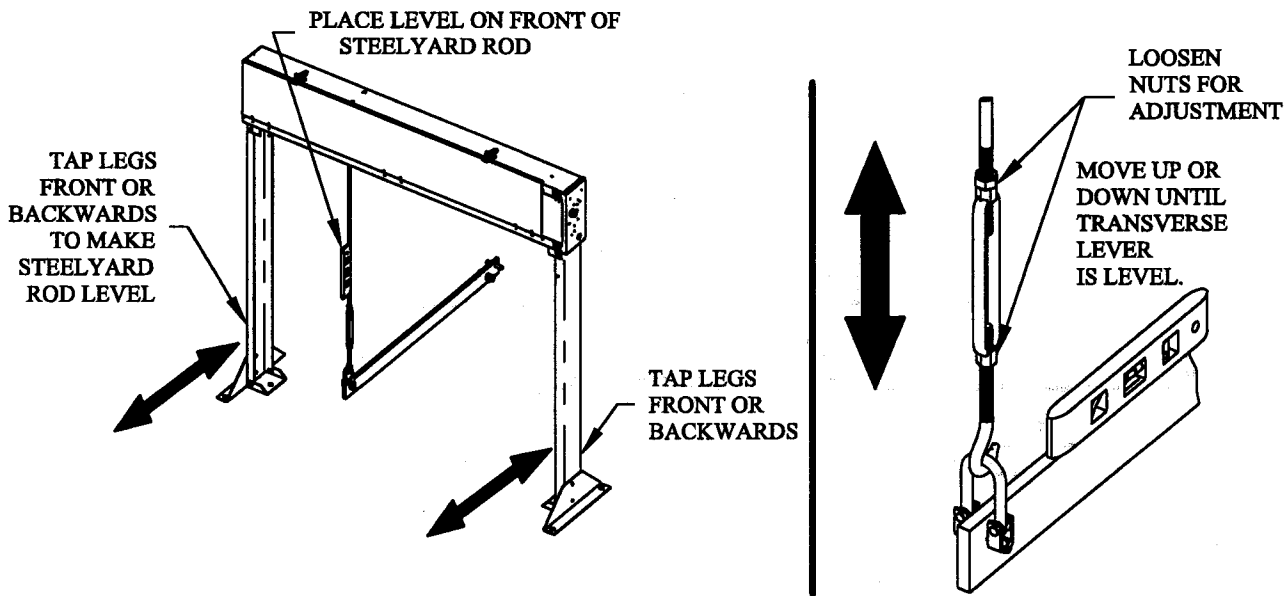

FIG. 14A

FIG. 14B

STEP 15. Check that each shackle is hanging properly in the grooves of the pins. See Fig. 15A. Usually in each corner one shackle will be tight and one loose (sometimes both are tight, this is okay). Place a square against the tight shackles and bottom plate. If shackle isn't square, lightly tap edge of bottom plate until it is squared up. See Fig. 15B.

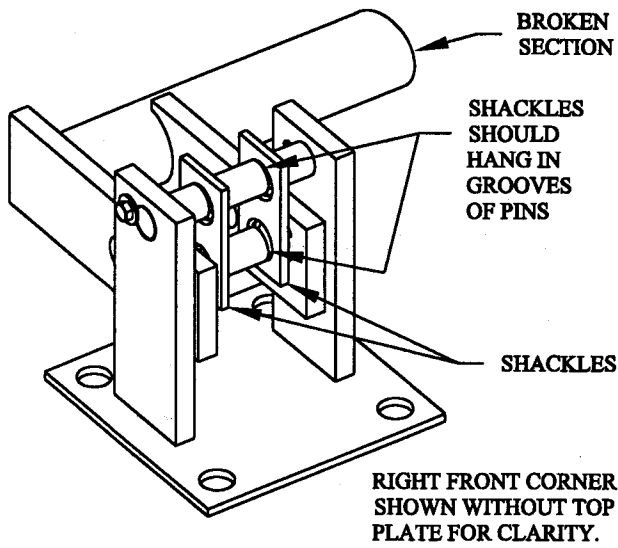

FIG. 15A

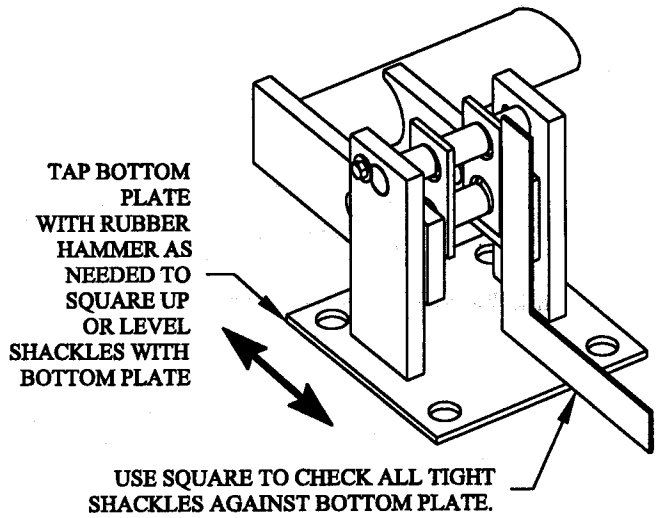

FIG. 15B

STEP 16. Repeat step 15 until all shackles are done. There are four shackles found at each corner and two shackles in the middle. All in all, there are 18 shackles. See Fig. 16.

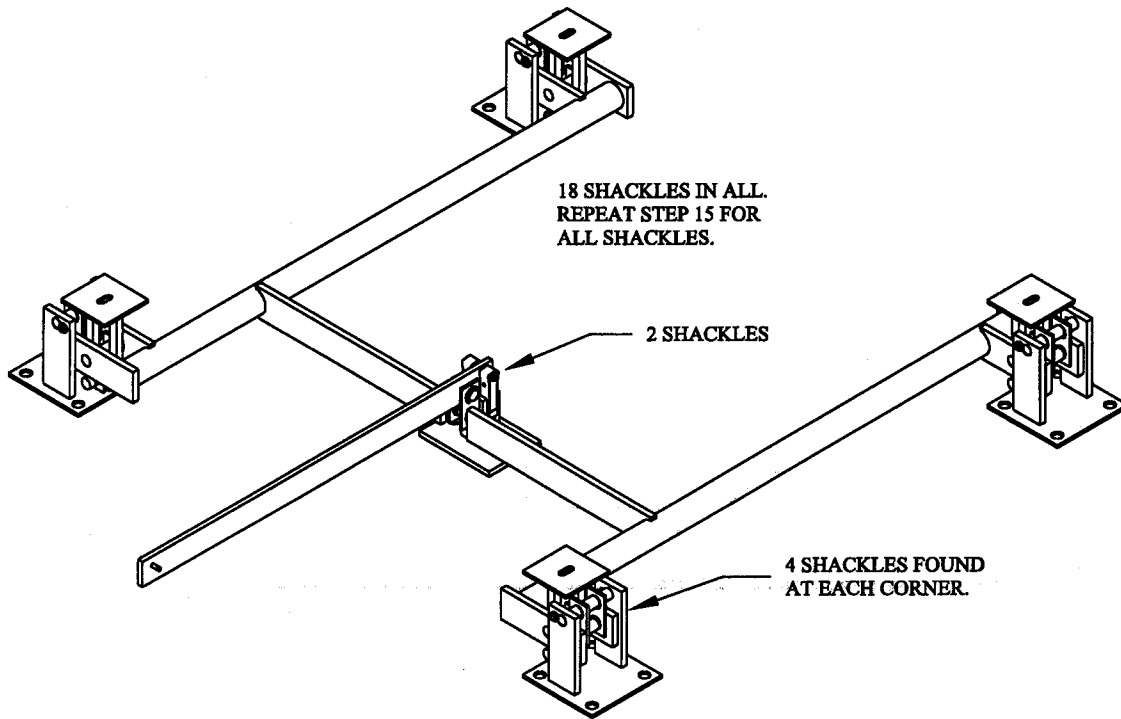

FIG. 16

STEP 17. Check all corners and middle section (transverse lever) to be sure that all parts (shackles and levers) are free and not rubbing anything. If one part is touching another, tap the bottom plate with a rubber hammer in the proper direction until parts no longer touch. See Fig's. 17A-17C.

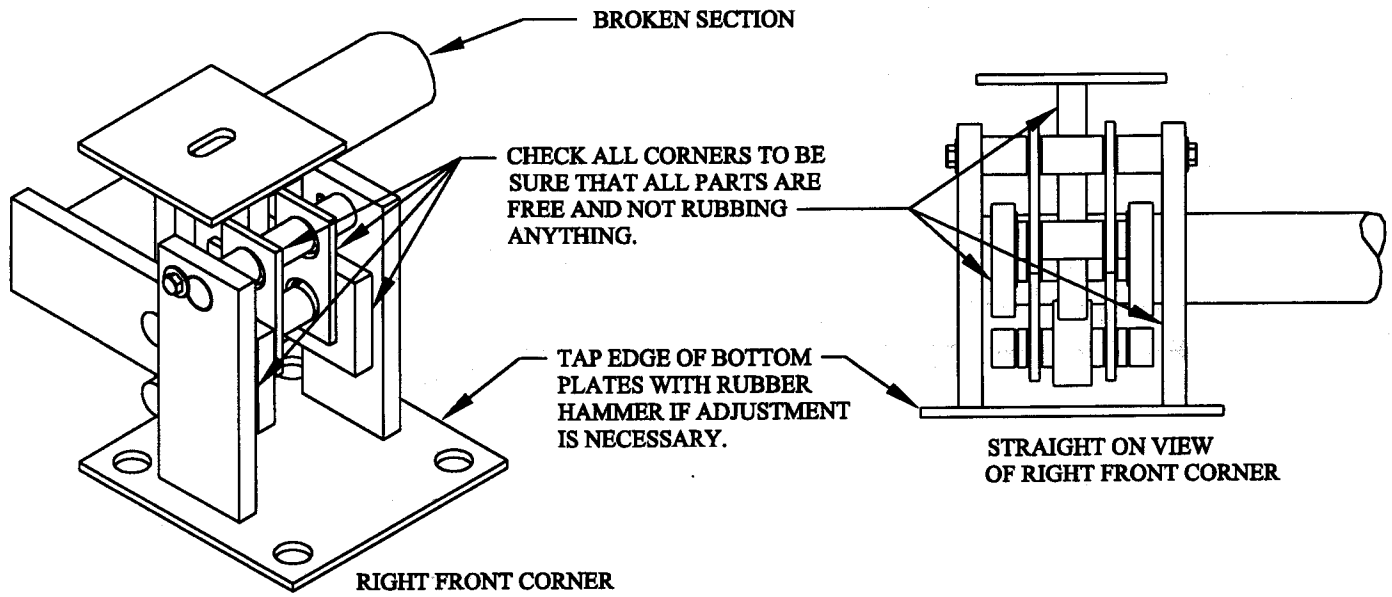

FIG. 17A

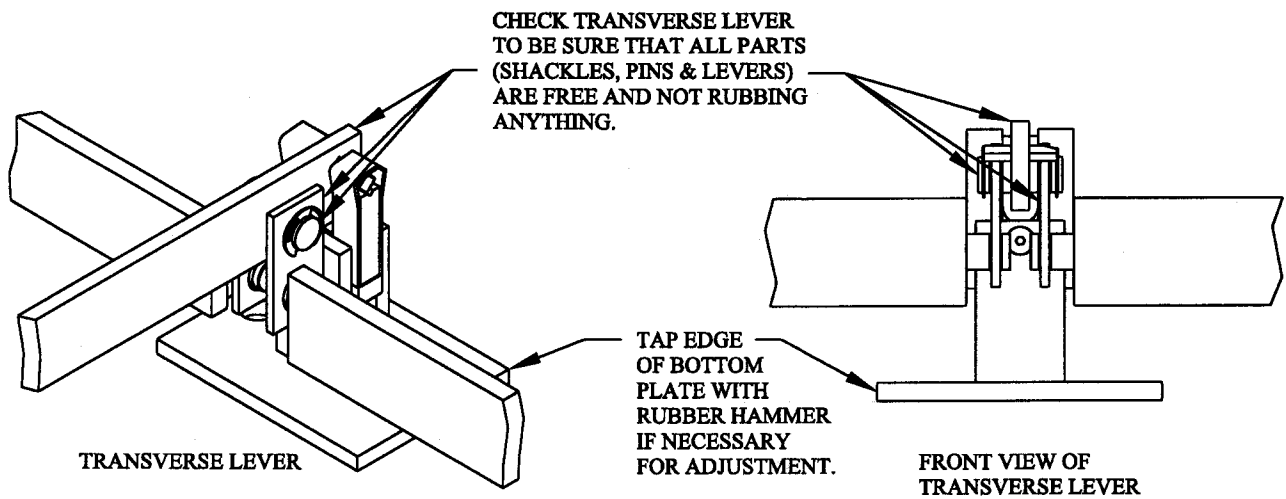

FIG. 17B

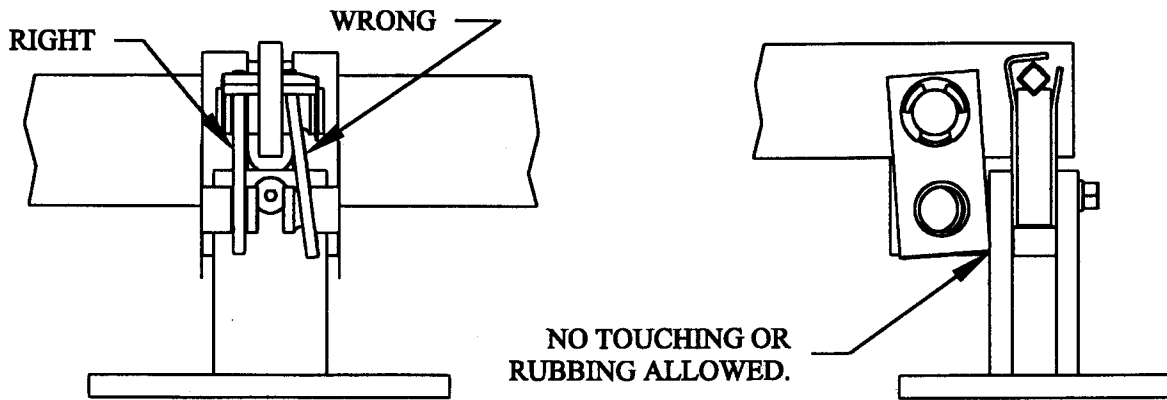

FIG. 17C

STEP 18. Tighten anchor bolts that are already in place or remove rods (whichever were used, see Step 12). Use a hammer drill to drill holes for anchor bolts. It is only necessary to use three at each of the four corners. There should be two at the transverse lever plate. See Fig. 18A. At the beam box legs (2) there should be three anchor bolts at each leg. See Fig. 18B. Make sure that all of the parts are still square and free hanging, as well as the steelyard rod being level front and sideways. The nuts provided for tightening the bin down can now be tightened.

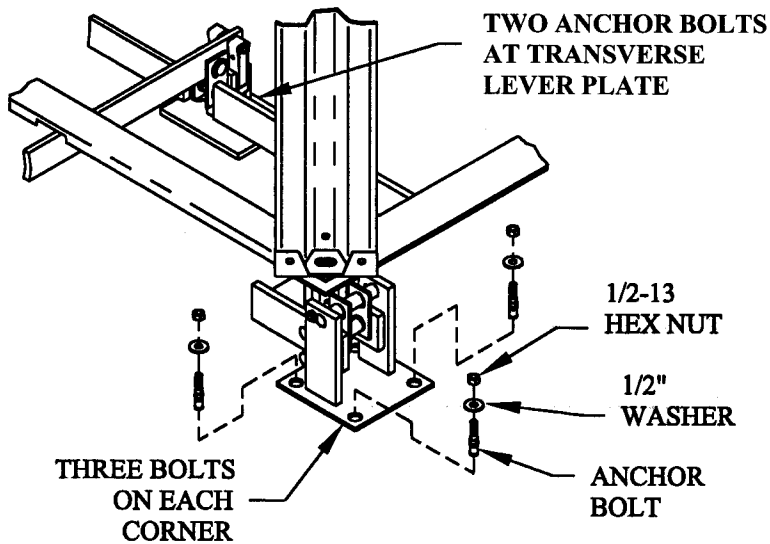

FIG. 18A

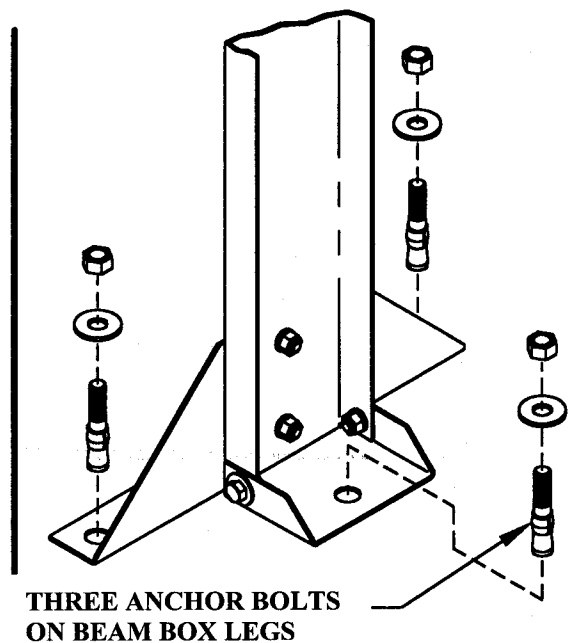

FIG. 18B

STEP 19. Check the beam to make certain that it doesn't touch or scrape against the trig loop as it moves up and down. See Fig 19A. To adjust the beam, first loosen the four bolts that hold the bracket that the beam pivots on, then rotate the bracket until the beam is corrected. Retighten the four bolts securely. See Fig. 19B.

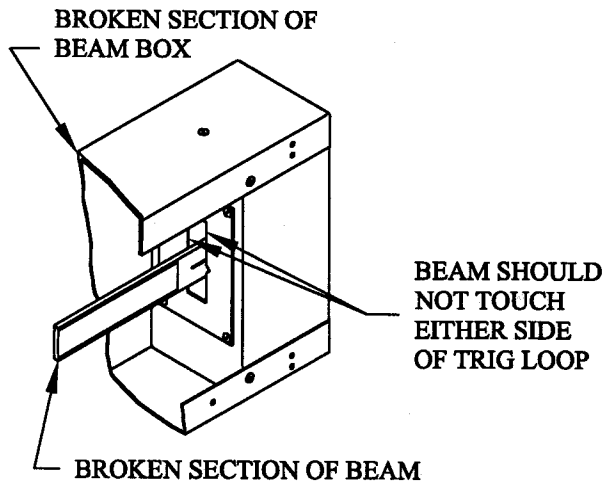

FIG. 19A

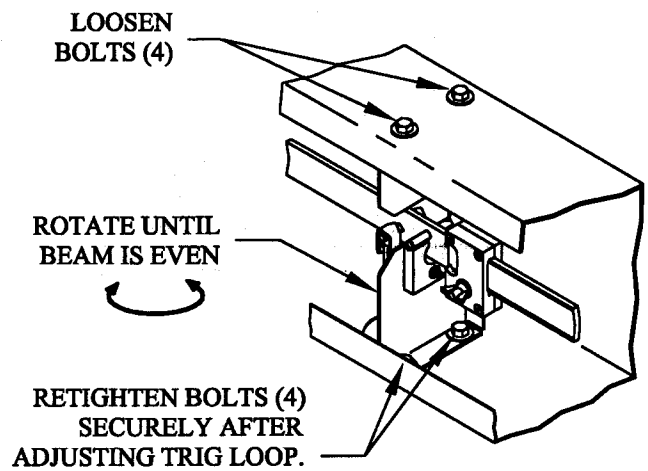

FIG. 19B

STEP 20. The mouseguard on the steelyard rod should not touch the bottom of the beam box (move the beam up and down to check). There should always be some clearance, but not enough for a mouse to crawl through, about 3/8" For adjustment, loosen the two screws on the mouseguard and slide mouseguard up or down the steelyard rod as needed. Retighten the two screws securely. See Fig. 20.

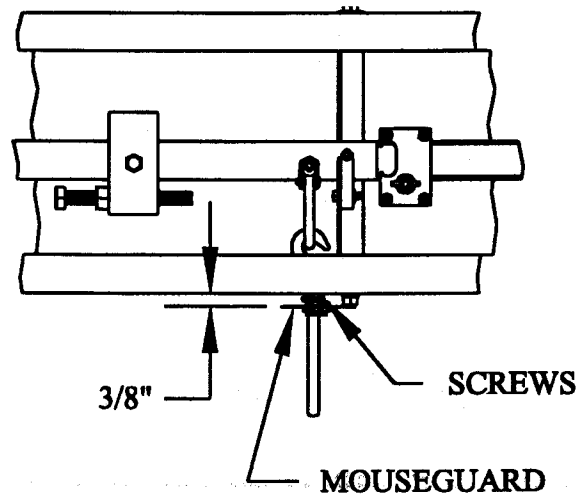

FIG. 20



STEP 21. Push upward on the bin. If it rocks up and down, this may be because the concrete isn't level. This is easily corrected. At each corner, the two shackles should both be tight or more often the case, one will be tight and one loose. Check each corner and find where two shackles are loose (this is where the bin is rocking). Loosen the nut on the bin leg. Slide a bin shim(s) under bin legs. See Fig. 21.

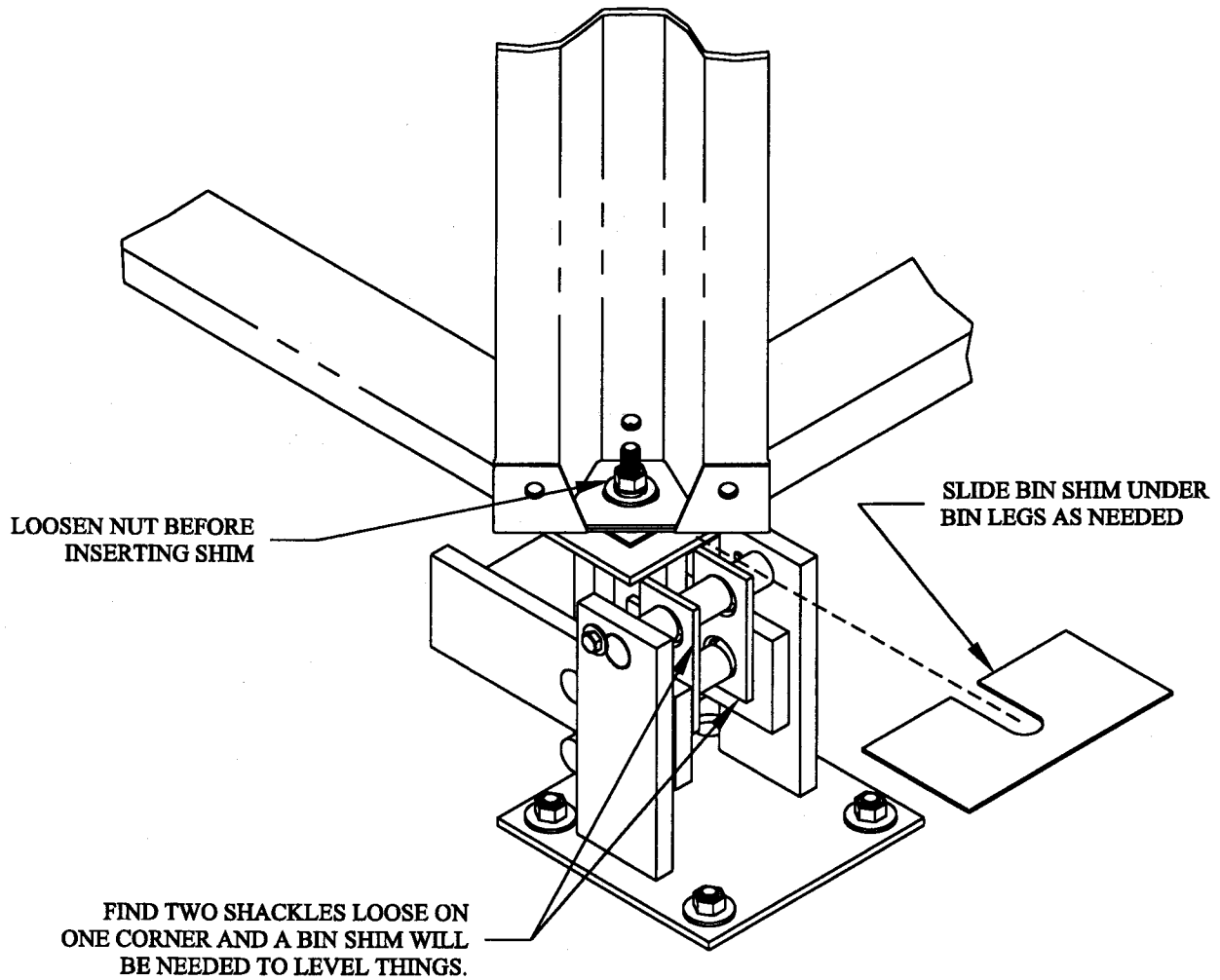

FIG. 21

# CALIBRATION INSTRUCTIONS FOR 5 & 10K BIN SCALE

Note: Control box must be wired and feed must be in the storage bin before proceeding.

STEP 1. Check the scale installation. All parts should be free moving, square and level. Inspect beam, whiskers & micro switches; they can be seen through opening in trig loop. See Fig. 1A & 1B. If adjustment is necessary (see step 2) turn screws on door to move whiskers. Only the screws (2) on the decals will work. See Fig. 1C.

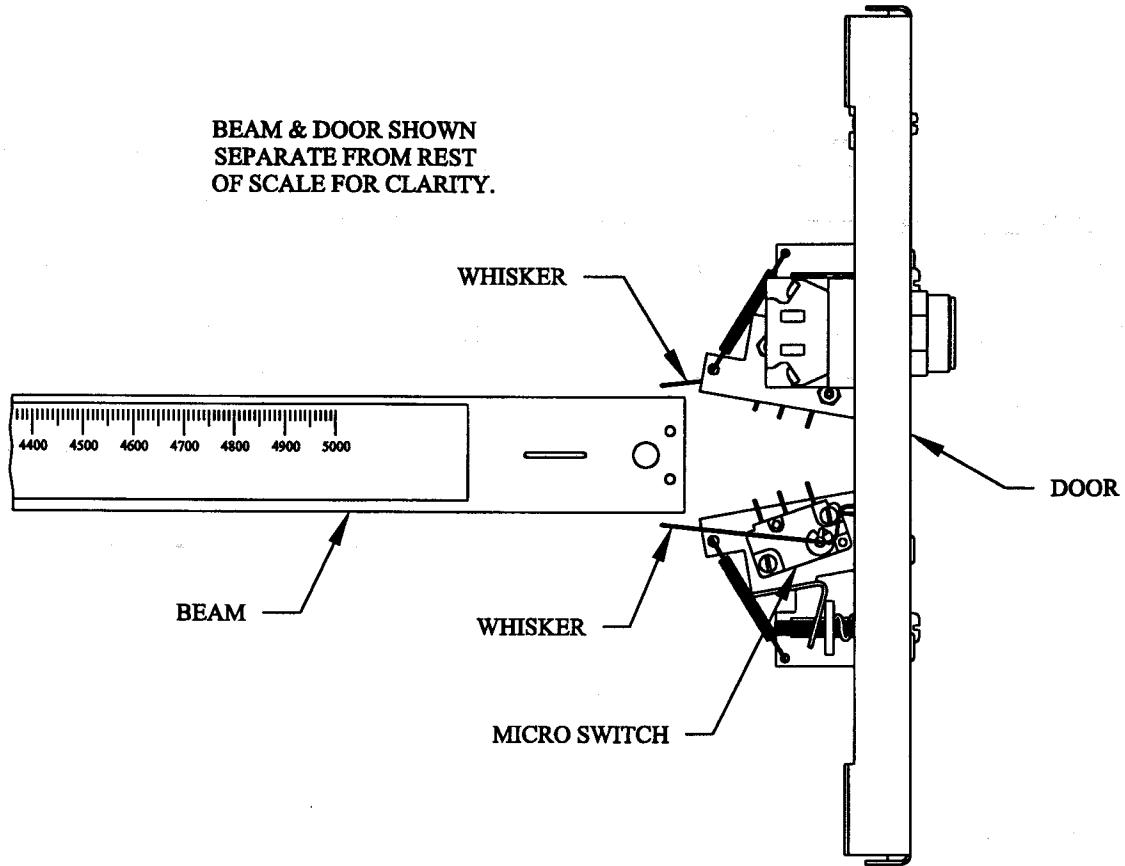

FIG. 1A

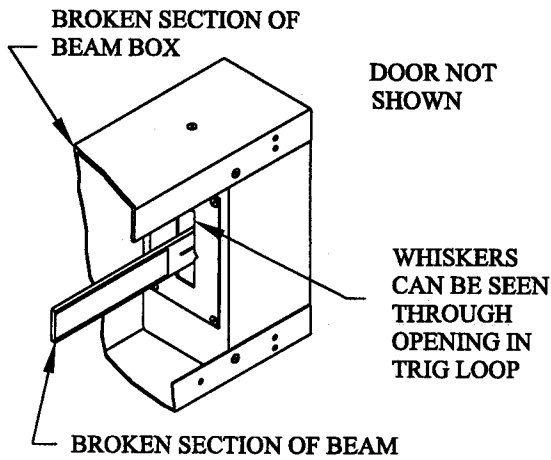

FIG. 1B

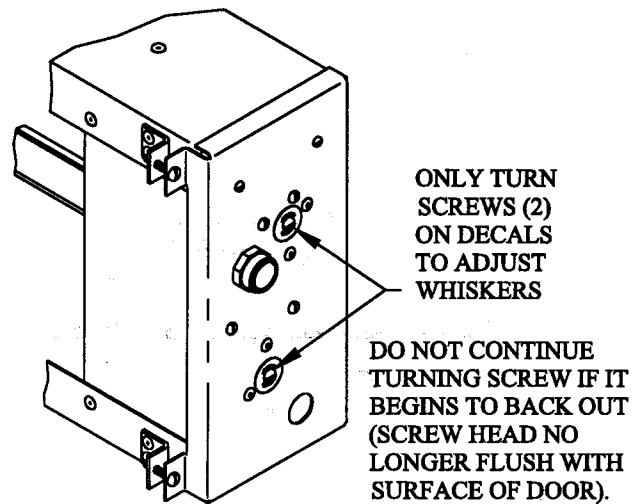

FIG. 1C

STEP 2. Check the adjustment of the micro switches. They should be set so that they trip when the beam moves either up or down approximately 1/4" from its center position. See Fig. 2A. If fill system shuts off before desired weight is in bin, turn bottom screw (with decal) counter-clockwise to correct or clockwise if too much weight goes into bin (refer back to Fig. 1C for right screws). If feed system shuts off before desired weight is distributed, turn top screw (with decal) counter-clockwise to correct or clockwise if too much feed is getting distributed. It may be possible (but unlikely) that the screw does not move the whiskers if the push pivot isn't touching the micro switch bracket. In this case, turn the screw counter-clockwise. The push pivot will eventually engage the micro switch bracket and the whisker will start moving. See Fig 2B.

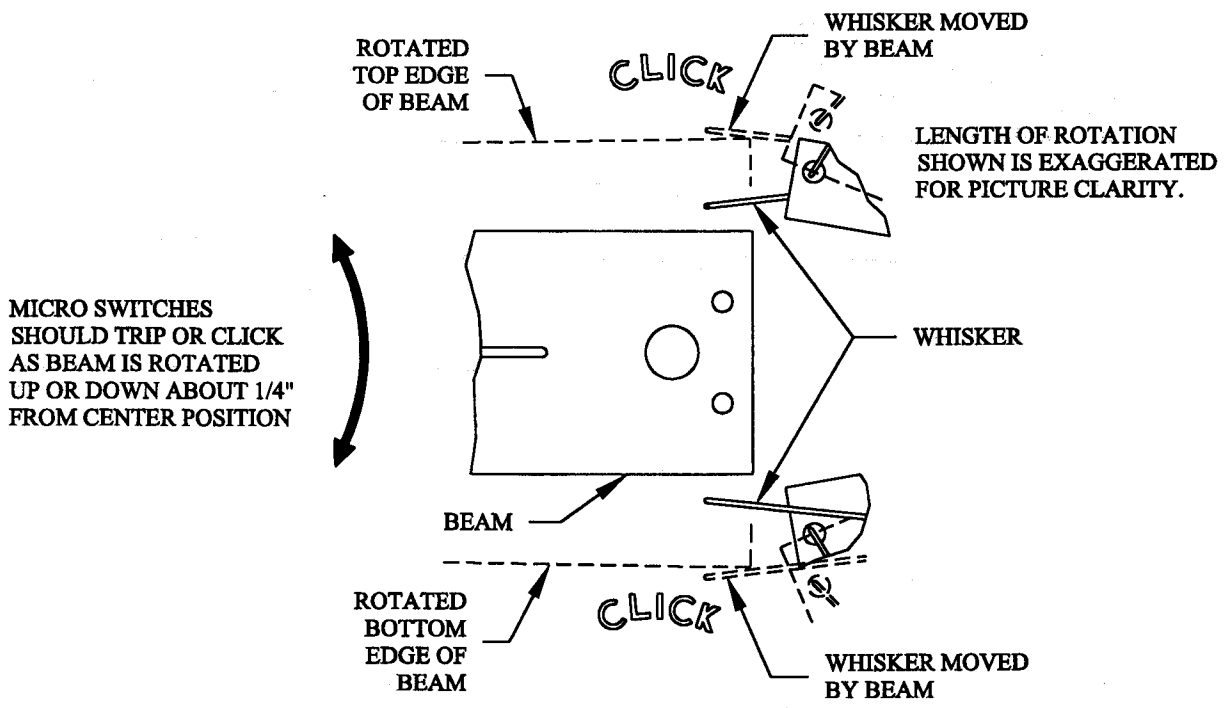

FIG. 2A

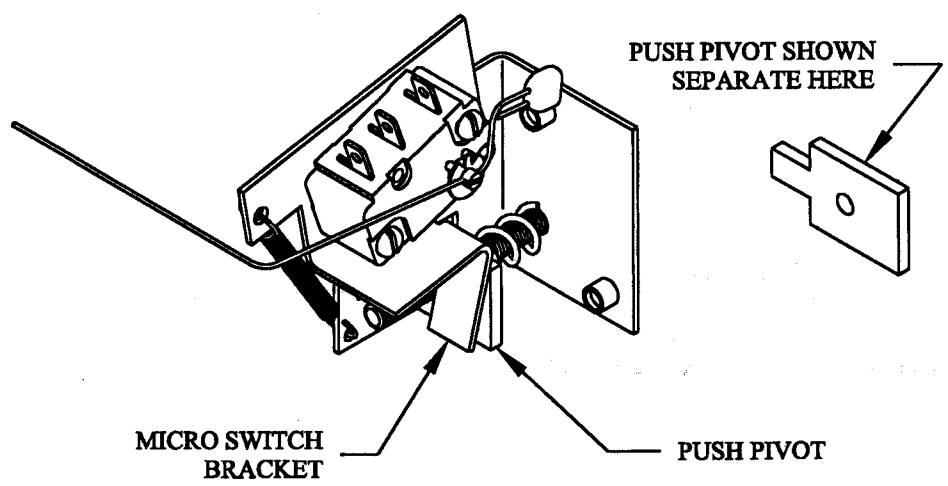

FIG. 2B

STEP 3. Move the LB/KG poise weight on the beam to zero. Tighten securely. See Fig. 3A. There is a tendency to move the beam back against the bearing when the poise is moved. Be certain the beam is centered after each time the poise is moved. See Fig. 3B. The 10000# & 20000# beams have two poises and each must be set to zero. A 10000# beam is shown in Fig. 3C.

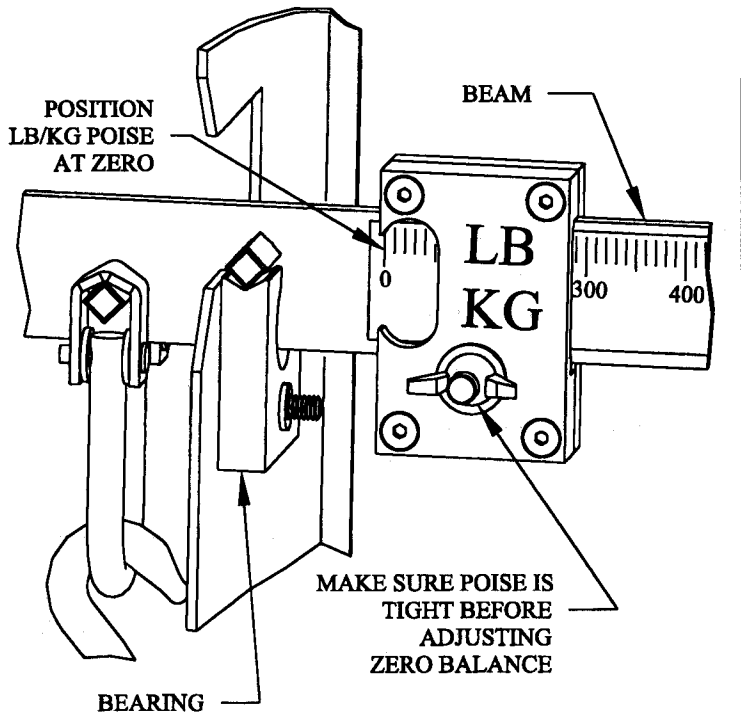

FIG. 3A

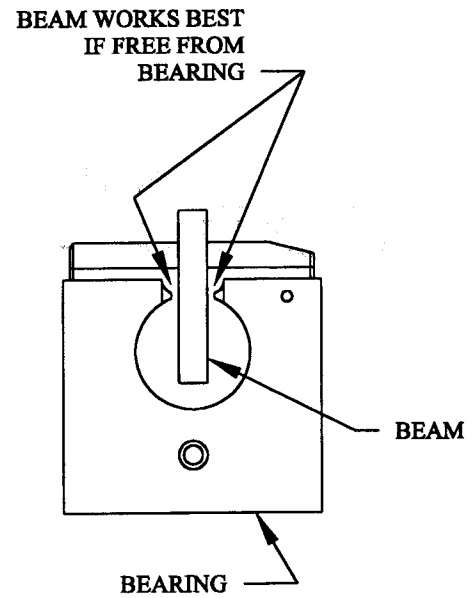

FIG. 3B

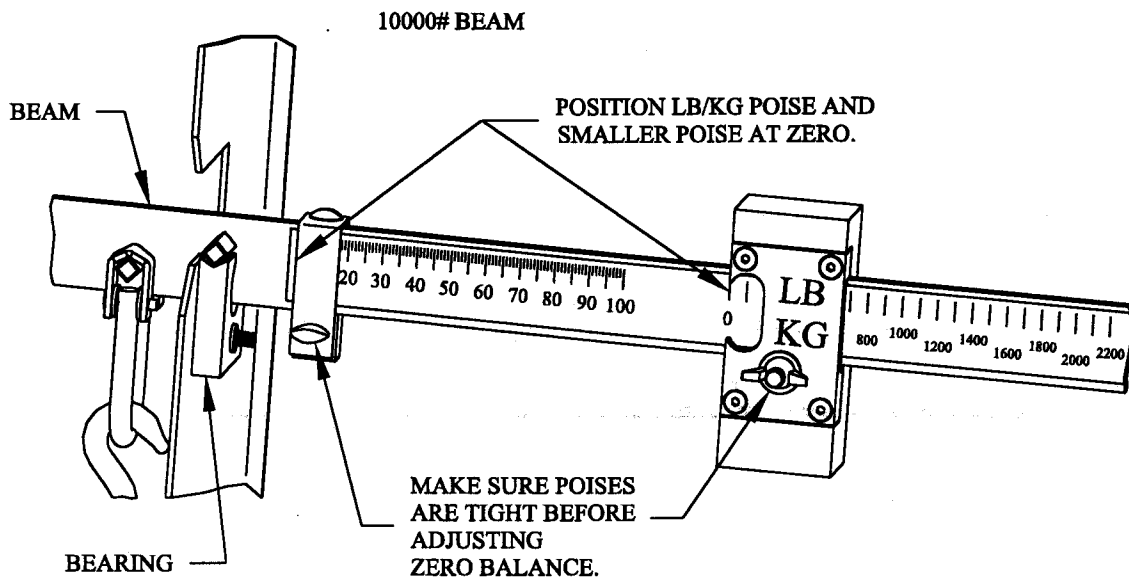

FIG 3C

STEP 4. Adjust the back balance block on the beam so that the beam floats in the center of the trig loop. Tighten the hex bolt with a 9/16" wrench to lock the block on the beam. Make fine adjustments with the 1/2" all threaded screw and tighten with a 3/4" wrench snugly. (Do not overtighten). See Fig. 4A & 4B. There are two back balances on a 10000# & 20000# beam. See Fig. 4C.

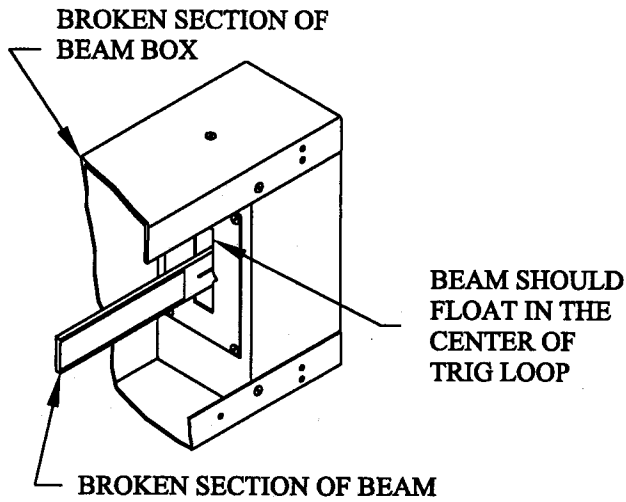

FIG. 4A

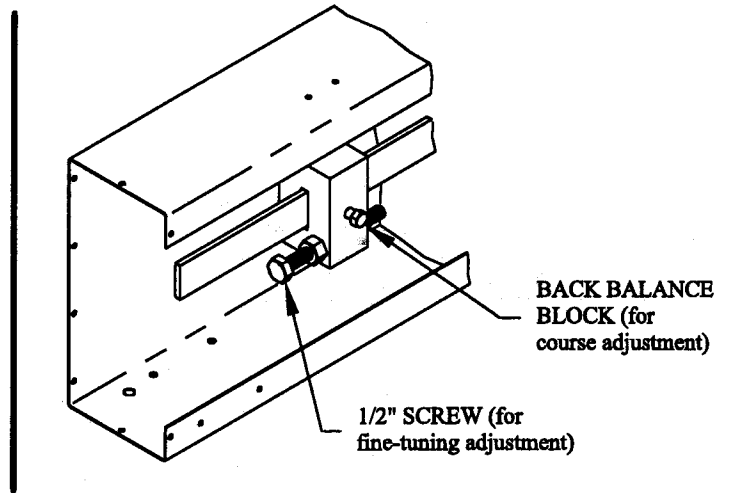

FIG. 4B

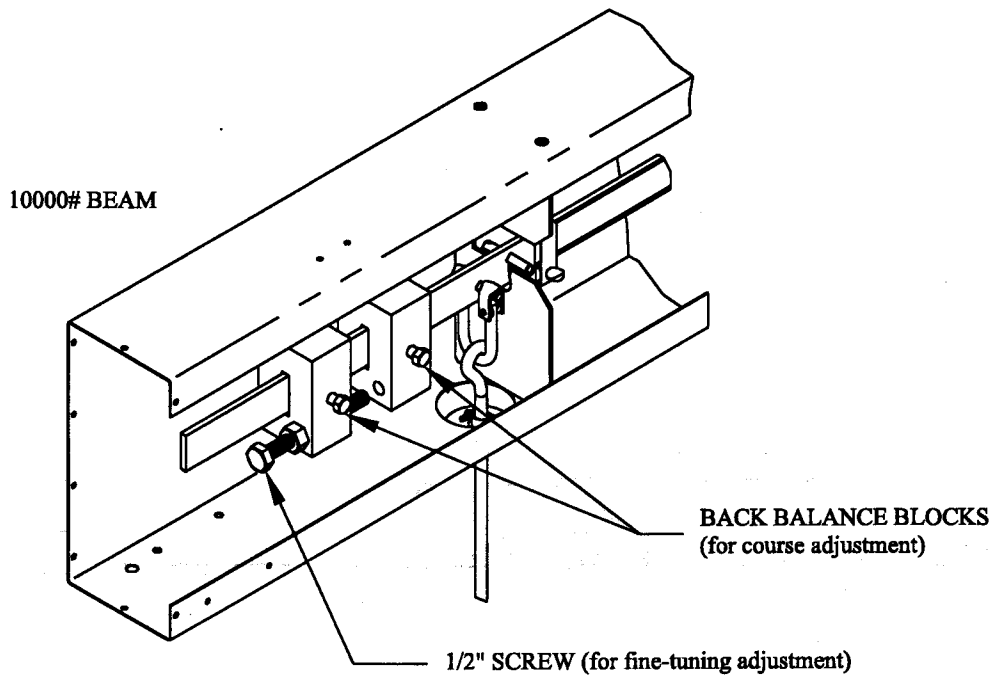

FIG. 4C

STEP 5. Slide the poise weight to 200 pounds on the beam. See Fig. 5A. Beam will drop down. Start the fill system with the green push button on the side door. See Fig. 5B. The fill system should shut off automatically when the bin has 200 pounds in it.

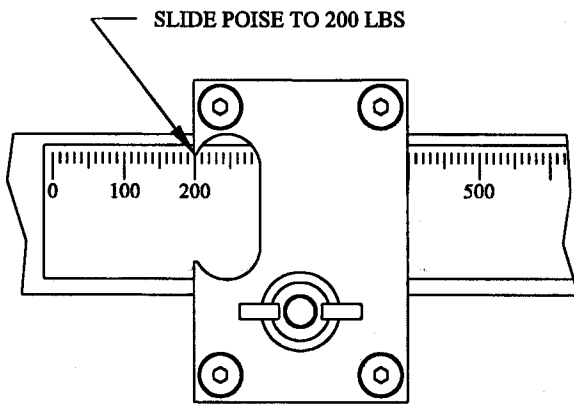

FIG. 5A

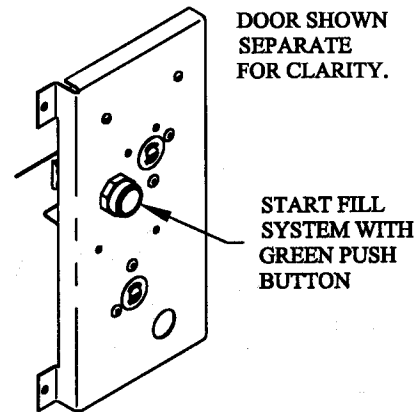

FIG. 5B

STEP 6. Manually run the feed line fill systems until the feed just starts to come out of the dropouts in the augers. See Fig. 6. This will charge the feed lines for daily operation.

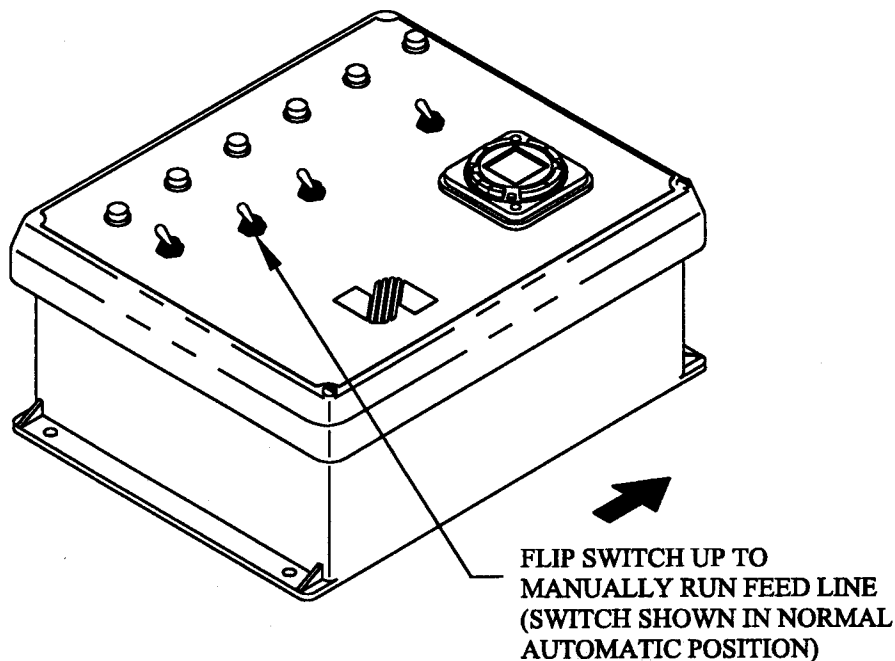

FIG. 6

STEP 7. Turn the feed line fill systems off at the control box. Move the poise back to zero. Reset the back balance as instructed in step 4. The scale is now balanced with a small amount of feed left in the bin.

STEP 8. Set the time clock for the desired times of feed line operation. System is now ready for operation.

## TERMINAL STRIP WIRING

- #1. LOWER LIMIT SWITCH - RED N/O – KEEPS WEIGH BIN FILL SYSTEM RUNNING (AFTER START BUTTON TURNS IT ON)
  - #2. LOWER LIMIT SWITCH – YELLOW N/C – TURNS ON “READY” LIGHT
  - #3. UPPER LIMIT SWITCH - ORANGE N/O – TURNS ON FEED LINE FILL SYSTEM
  - #4. START BUTTON – BLUE N/O – TURNS ON WEIGH BIN FILL SYSTEM (IF #1 IS NOT ENGAGED, FILL SYSTEM WILL NOT STAY ON AFTER BUTTON IS RELEASED)
  - #5. COMMON ALL SWITCHES – BLACK – RUNS ELECTRICITY TO SWITCHES & START BUTTON.
- Note: When hooking to Spinks Scale control box, wiring is simplified by hooking red to red, yellow to yellow, orange to orange, blue to blue, and black to black.

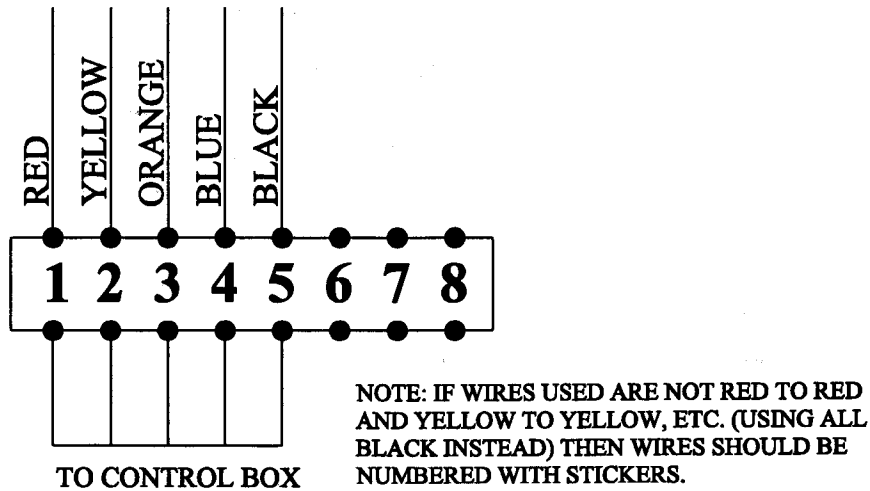

FIG. 1

Note: For Choretime or Roxell, ignore yellow wire. Move black wire that connects #5 to upper limit switch from #5 to #7. See Fig. 2.

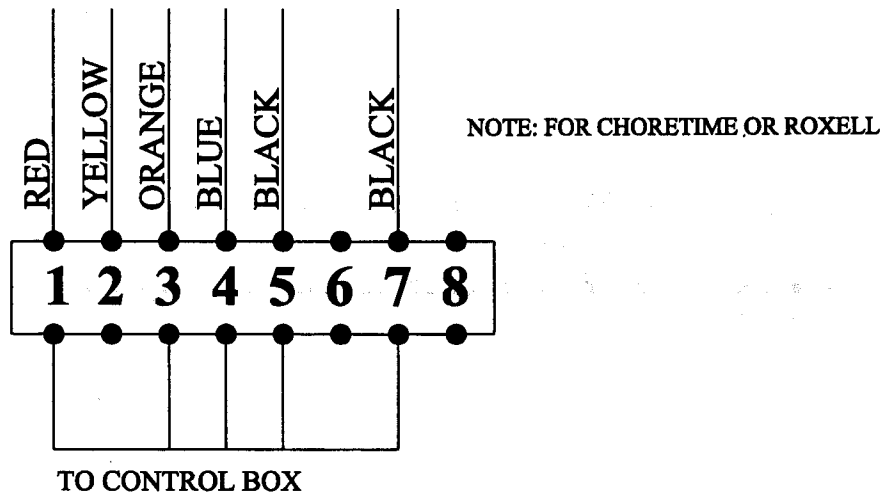

FIG. 2

## DAILY OPERATION

STEP 1. Set the poise on the beam to the desired amount of feed needed for the day. See Fig. 1A. The beam will swing down engaging the bottom whisker and switch. 10000# & 20000# scales have different beams. Setting the weight for a 10000# beam is shown in Fig. 1B. The 20000# beam is similar to the 10000# and is not shown.

STEP 2. Start the weigh bin fill system by pushing the green button located on the side door. See Fig. 2 (shown twice). The weigh bin fill system will shut off automatically when the correct weight set on the beam is reached.

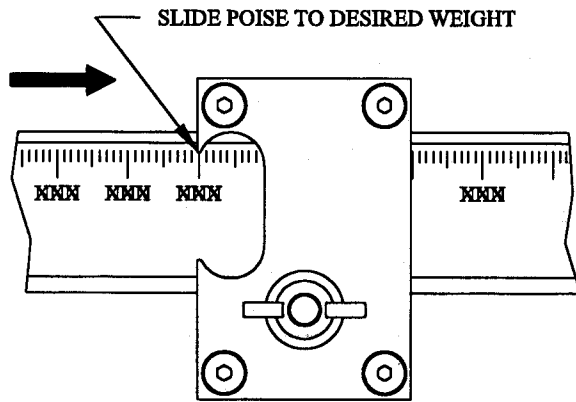

FIG. 1A

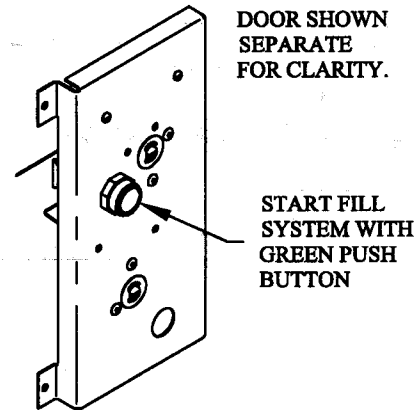

FIG. 2

10000# BEAM SHOWING 1,040 POUNDS (EXAMPLE). THE BIG LB/KG POISE IS SET ON 1000 POUNDS AND THE LEFT SIDE OF THE SMALL POISE IS ON 40 POUNDS ( $1,000 + 40 = 1,040$ ).

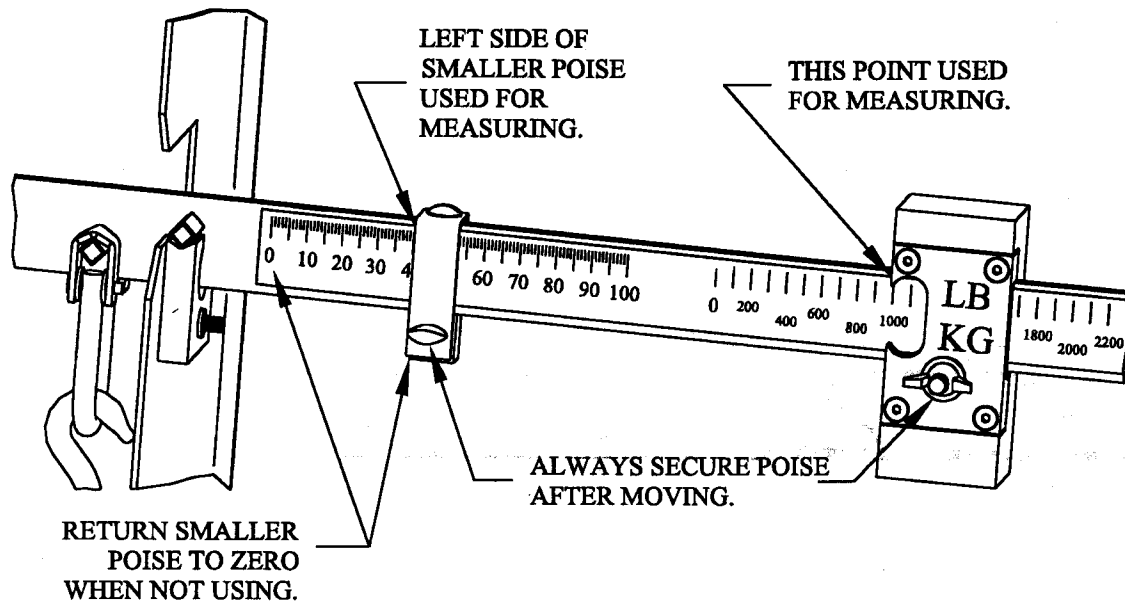

FIG. 1B

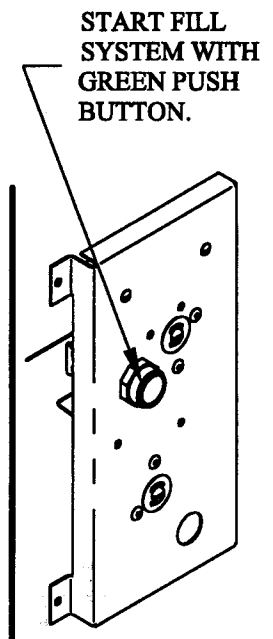

FIG. 2



STEP 3. Slide the poise back to zero on the beam. See Fig. 3A. For a 10000# beam slide both poises back to zero. See Fig. 3B.

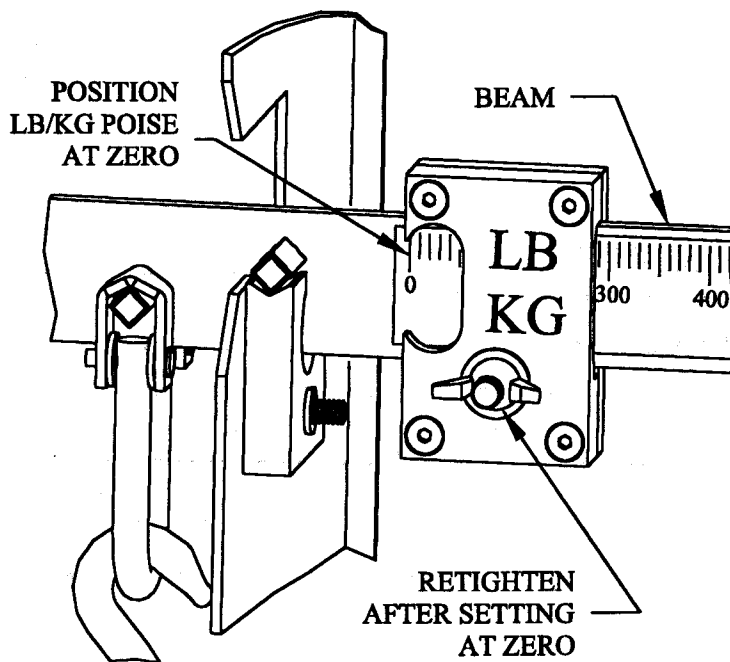

FIG. 3A

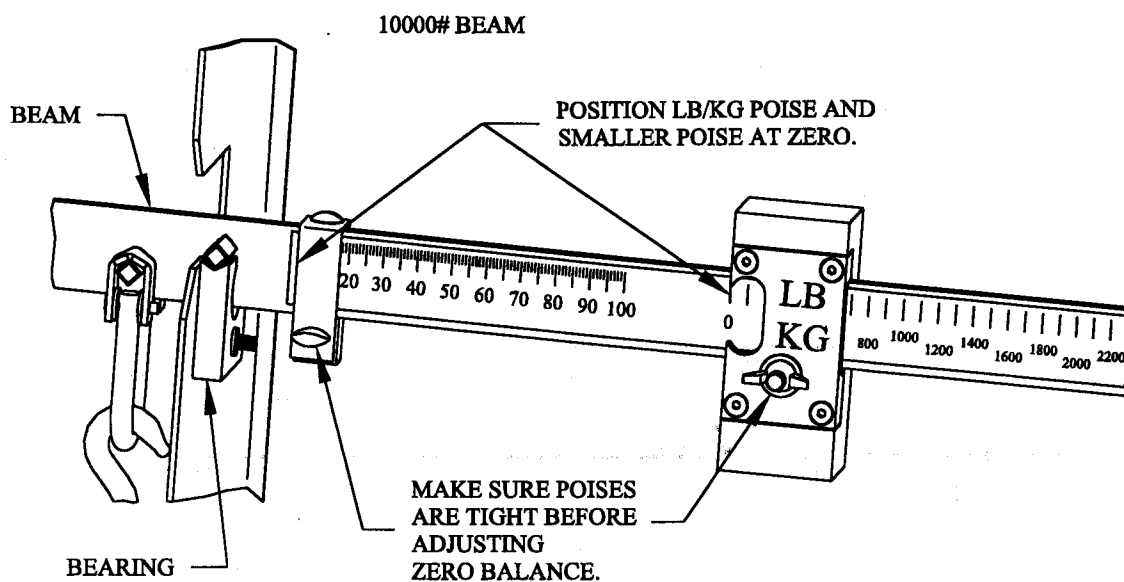

FIG. 3B

(Step 3 Continued) The beam will swing up engaging the top microswitch, causing the feed line fill systems to automatically come on (see Fig. 3C), unless a Chore-Time control box is being used. If a Chore-Time control box is in use, the fill systems will automatically come on when the time clock calls for it. The fill systems will run until the level switch in the feed line hoppers cuts them off.

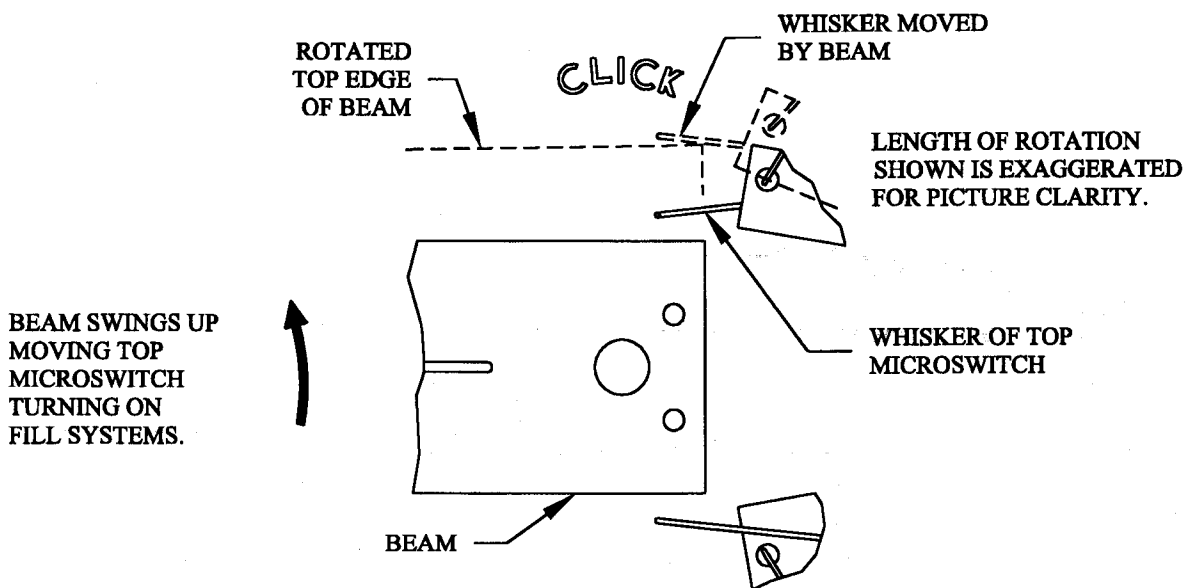

FIG. 3C

STEP 4. The feed lines will come on at the time set on the clock. The level switches in the feed line hoppers will control the fill system motors on and off until the beam reaches the center of the trig loop (or comes to rest between microswitches) shutting off the fill systems completely. See Fig. 4.

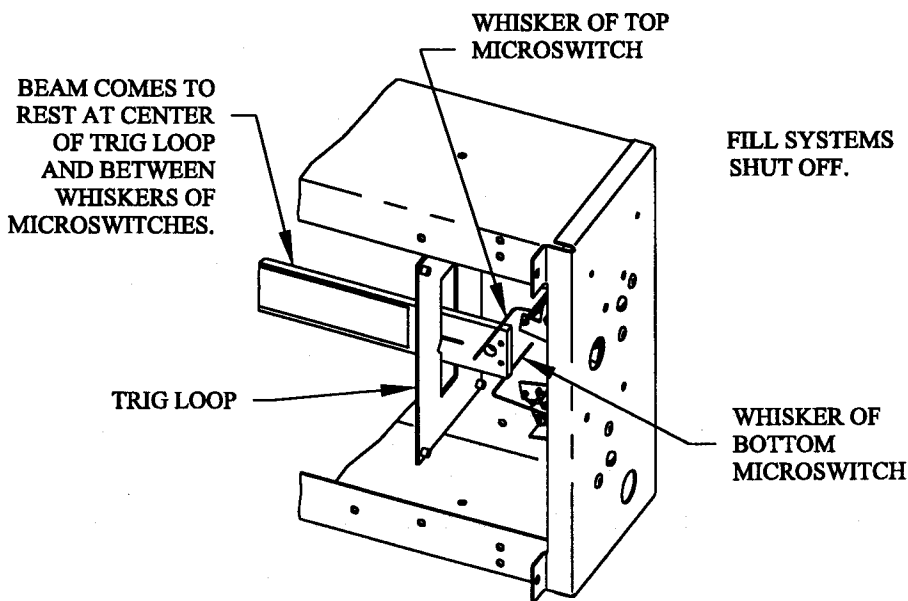

Fig. 4

You are now ready for the next day's operation.

## SCALE INSTALLATION CHECKLIST

- 1) After the scale and augers are installed make a final inspection. Make sure the augers have 1/2" clearance going through the wall of the house. See Fig. 1.
- 2) Check to make sure the scale floats, if not see Fig's. 17A-C and Fig's. 12B-C, make adjustment as necessary.
- 3) Make sure that the steelyard rod is plumb in both directions. Left to right and front to back. See Fig's. 13 & 14A.
- 4) Make sure that the transverse lever is level and the arrows on the decal are pointing up. "This is very important." See Fig. 14B.
- 5) Make sure that bin does not rock diagonally. To check this, step on each corner of the bin leg. If it rocks, shims are needed. See Fig. 21.
- 6) Check to make sure that the beam is not touching the sides of the trig loop. See Fig. 19A & 19B.
- 7) Sometimes, if the fill system is installed after the scale is bolted down, it may cause the bin to shift with the scale. Check the 3/4" x 3/4" square bar that is under each bin leg. Make sure it is not touching the 1" round pin. If it is touching, loosen the bolt that holds the bin to the top mounting plate; shift the top mounting plate so that there is about 1/4" clearance. See Fig's. 12B-12C. Check all 4 corners.
- 8) Balancing the scale for the first time to zero. Slide the poise to zero on the beam and tighten. See Fig. 3A (Calibration section – pages 18-22). Loosen the back balance set screw and move the block forward or backward to get the beam close to balancing. Tighten the set screw. Use the 1/2" screw for the final balance. Tighten the 3/4" nut. See Fig.4B (Calibration section – pages 18-22). Make sure the beam floats freely and repeats.
- 9) Check the micro switches, if both whiskers are touching the beam at the same time they need to be adjusted, See Fig. 2A (Calibration section – pages 18-22).
- 10) Charging the system. Set the poise to 200 lbs. Start the fill system motor, the motor will stop when the 200 lbs. is reached. Slide the poise back to zero. Run the cross fill motors until feed is flowing out, stop the motors, and rebalance the scale to zero. The scale is now ready for use.

# SPINKS SCALES

INSTRUCTIONS/OPERATIONS MANUAL

For

**BIN SCALES**

**MODELS:**

**5,000 #**

**10,000 #**

